

DFDK Series Inline Duplex Filters 4500 psi • up to 90 gpm

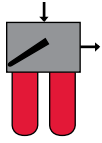

Hydraulic Symbol

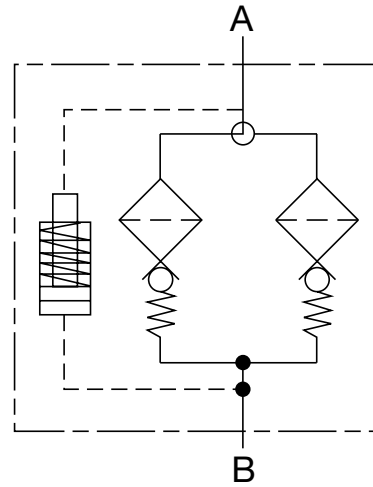

Features

- The DFDK Filters have a filter head of ductile iron and a screw-in bowl of cold-formed steel.
- The filter housings are designed to withstand pressure surges as well as high static pressure loads.
- The screw-in bowl allows the filter element to be easily removed for replacement or cleaning.
- A visual (*pop-up*), electrical, electrical/visual (lamp), or other electronic differential types of clogging indicators are available to suit each application.
- DFDK filters are available only with high collapse pressure elements since no bypass is provided.

Technical Details

Mounting Method	4 mounting holes	
Port Connection	60/110 SAE-12 160/240/280 SAE-24 330/660/1320 2" SAE-32 Flange Code 62	
Flow Direction	60 - 280	330 - 1320
Inlet	Top	Top
Outlet	Side	Back
Construction Materials	Head Ductile iron Bowl Steel Housing (1320) Steel Cap (1320) Ductile iron	
Flow Capacity	60/110 13 gpm (50 lpm) 160/240/280 35 gpm (132 lpm) 330/660/1320 90 gpm (340 lpm)	
Housing Pressure Rating	Max. Operating Pressure 4500 psi (315 bar) Proof Pressure 6800 psi (475 bar) Fatigue Pressure Contact HYDAC Office Burst Pressure > 18,270 psi (1260 bar)	
Element Collapse Pressure Rating	BH/HC, V 3045 psid (210 bar)	
Fluid Temperature Range	-22° to 250°F (-30° to 121°C)	
Fluid Compatibility	Compatible with all petroleum oils and synthetic fluids rated for use with Fluoroelastomer or Ethylene Propylene seals. Contact HYDAC for information on special housing and element constructions available for use with water glycols, oil/water emulsions, and HWBF.	
Indicator Trip Pressure	ΔP = 116 psid (8 bar) -10% (standard)	

Applications



Automotive



Industrial



Power Generation



Pulp & Paper



Railways



Steel / Heavy Industry

Model Code

DFDK BH/HC 60 Q A C 3 A 1 . 0 -

Filter Type _____
DFDK = Duplex Pressure Filter with Ball Valve Selector

Element Media _____
BH/HC = Betamicon® (High Collapse) **V = Metal Fiber**

Size _____
60, 110, 160, 240, 280, 330, 660, 1320 (larger sizes available - contact HYDAC)

Pressure Range _____
K = 2320 psi (160 bar) (sizes 1320 - 3960 with type code 3 only)
Q = 4568 psi (315 bar) (sizes 30 - 1320 with type code 1 or 2 only)

Valve _____
A = Ball Valve

Connection _____
B = SAE 8 (size 30 only) L = 2" SAE Code 62 (sizes 330 - 1320 only)
C = SAE 12 (sizes 60/110 only) M = 2 1/2" SAE Code 62 (sizes 1320 only)
F = SAE 24 (sizes 160 - 280 only)

Filtration Rating (micron) _____
3, 5, 10, 20 = BH/HC **3, 5, 10, 20 = V**

Type of ΔP Clogging Indicator _____
A, B/BM, C, D

Type Number _____
1 = One Piece Bowl (sizes 60 - 660 only)
2 = Two Piece Bowl (size 280, 330, 660, 1320 only)
3 = Upside down mounting - Element top access (size 1320 only)

Modification Number (latest version always supplied) _____

Port Configuration _____
12 = SAE Straight thread O-ring Boss Ports (sizes 60-280 only)
16 = SAE Flange Ports (sizes 330-1320 only)

Seals _____
(omit) = Nitrile (NBR) (standard) **V = Fluoroelastomer (FPM)** **EPR = Ethylene Propylene (EPDM)**

Supplementary Details _____
L24, L48, L110, L220 = Lamp for D-type clogging indicator (LXX, XX = voltage)
W = Indicators with brass piston (for use with water based fluids)
SO155H = Modification of BH4HC Elements for Phosphate Esters.
T100 = Indicator Thermal Lockout, 100°F (C and D indicators only)

Replacement Element Model Code

0030 D 010 BH4HC / V

Size _____
0060, 0110, 0160, 0240,
0280, 0330, 0660, 1320

Filtration Rating (micron) _____
3, 5, 10, 20 = BH4HC
3, 5, 10, 20 = V

Element Media _____
BH4HC, **V**

Supplementary Details _____
(omit) = standard
V = Fluoroelastomer (FPM) seals

Clogging Indicator Model Code

VD 5 B . X /

Indicator Prefix _____
VD = G 1/2 6000 psi

Trip Pressure _____
8 = 116 psid (8 bar)

Type of Indicator _____
A = no indicator, plugged port
B/BM = Visual pop-up (auto/manual reset)
C = Electric switch
D = Electric switch and light

Modification Number _____

Supplementary Details _____
Seals
(omit) = Nitrile (NBR) (standard)
V = Fluoroelastomer (FPM)

Light Voltage (D type indicators only) _____
L24 = 24V L110 = 110V

Thermal Lockout (VM, VD types C, D, J, and J4 only) _____
T100 = Lockout below 100°F

Underwriters Approval (VM, VD types C, D, J, and J4 only) _____
CRUUS = Electrical Indicators
(For additional details and options, see Clogging Indicators section.)

Model Codes Containing RED are non-stock items — Minimum quantities may apply — Contact HYDAC for information and availability

Dimensions

DFDK 60 / 110 / 160 / 240 / 280

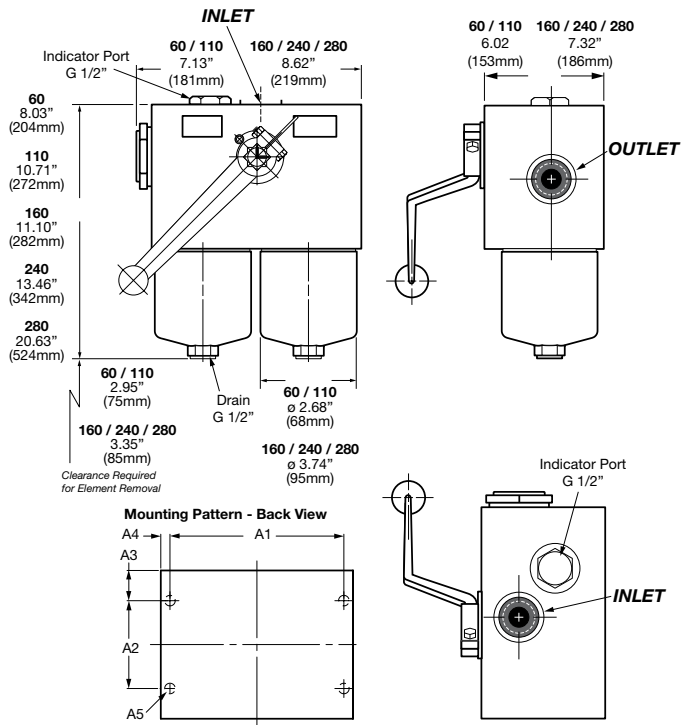

DFDK 330 / 660

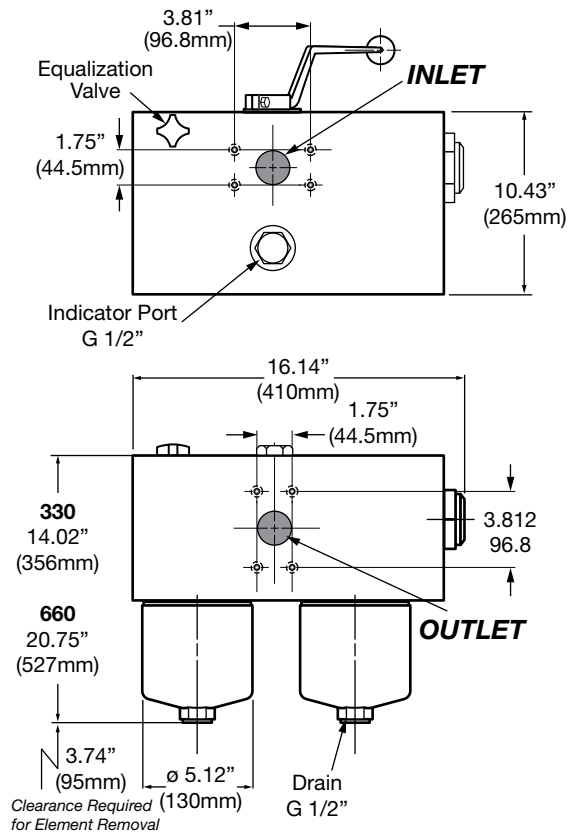

Size	A1	A2	A3	A4	A5
60/110	138 ± 0.2	78 ± 0.2	19	16	1/4"-28UNF-2Bx10DP
160/240/280	190 ± 0.2	96 ± 0.2	33	10	3/8"-24UNF11/16DP

DFDK 1320 - Back View

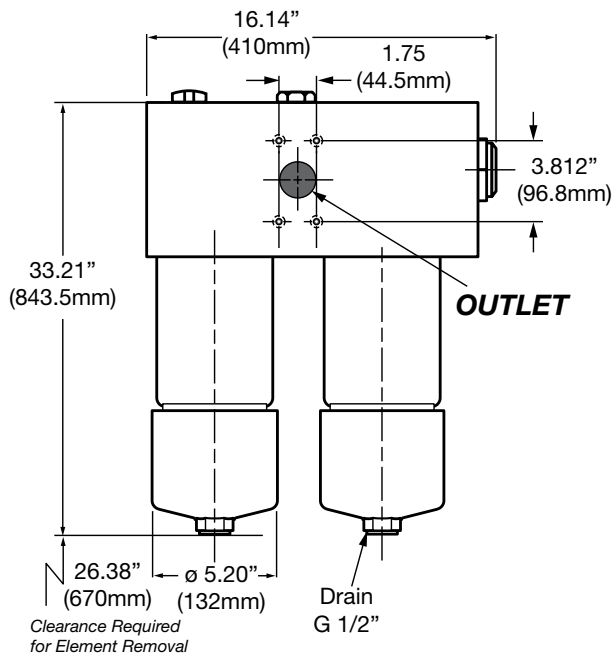

DFDK 1320 - Top View

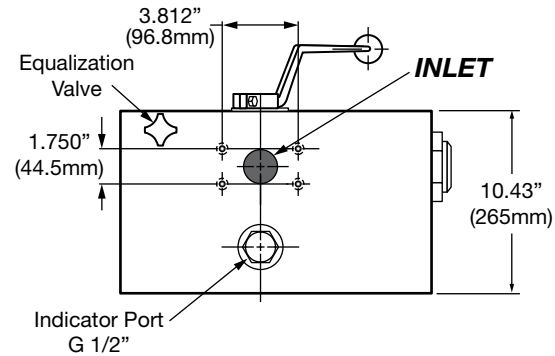

Flange Detail 330 / 660 / 1320

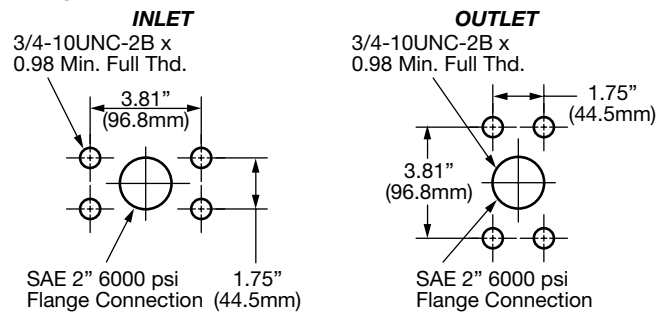

Size	60	110	160	240	280	330	660	1320
Weight (lbs.)	16.0	36.2	70.6	76.3	93.5	335.0	366.0	427.7

Dimensions shown are for general information and overall envelope size only. Weights listed are without element. For complete dimensions please contact HYDAC to request a certified print.

Sizing Information

Total pressure loss through the filter is as follows:

Assembly $\Delta P = \text{Housing } \Delta P + \text{Element } \Delta P$

Housing Curve:

Pressure loss through housing is as follows:

Housing $\Delta P = \text{Housing Curve } \Delta P \times \frac{\text{Actual Specific Gravity}}{0.86}$

Adjustments must be made for viscosity & specific gravity of the fluid to be used! (see sizing section on page 19)

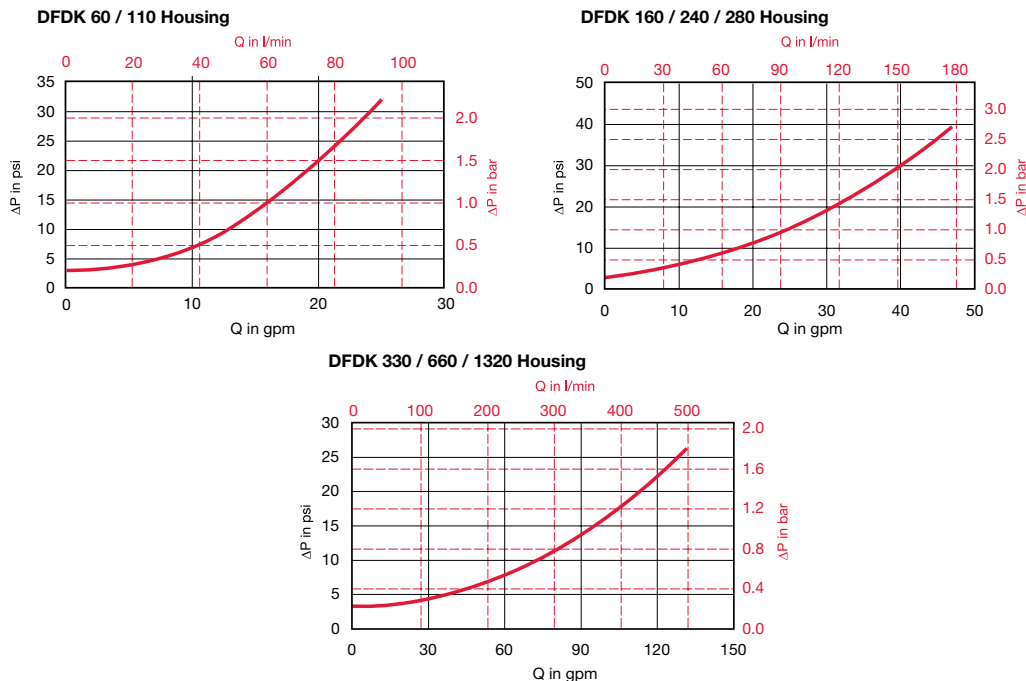

Element K Factors

$\Delta P \text{ Elements} = \text{Elements (K) Flow Factor} \times \text{Flow Rate (gpm)} \times \frac{\text{Actual Viscosity (SUS)}}{141 \text{ SUS}} \times \frac{\text{Actual Specific Gravity}}{0.86}$
(From Tables Below)

Size	...D...BH4HC (Betamicon® High Collapse)			
	3 μm	5 μm	10 μm	20 μm
0060	3.210	1.785	0.993	0.669
0110	1.394	0.819	0.488	0.307
0160	0.919	0.569	0.322	0.240
0240	0.578	0.374	0.214	0.158
0280	0.313	0.184	0.097	0.090
0330	0.422	0.244	0.154	0.108
0660	0.179	0.106	0.055	0.049
1320	0.089	0.054	0.031	0.024

Size	...D...V Elements			
	3 μm	5 μm	10 μm	20 μm
0060	0.877	0.511	0.296	0.183
0110	0.452	0.304	0.182	0.118
0160	0.251	0.177	0.123	0.079
0240	0.169	0.137	0.093	0.062
0280	0.126	0.093	0.064	0.041
0330	0.121	0.097	0.065	0.043
0660	0.063	0.050	0.034	0.021
1320	0.032	0.026	0.018	0.012

All Element K Factors in psi / gpm.