

DF...QE Series Manifold Mount Filters 4500 psi • up to 180 gpm

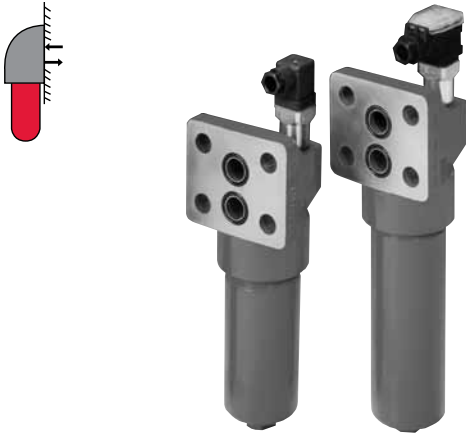

Hydraulic Symbol

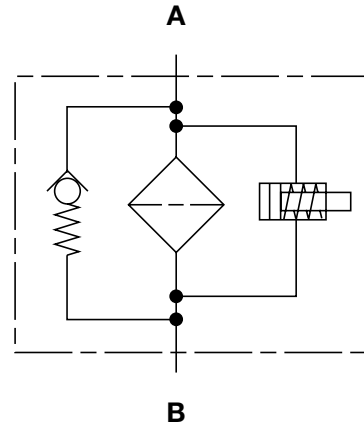

Features

- The DF...QE Filters have a filter head of ductile iron and a screw-in bowl of cold-formed steel for high fatigue strength.
- The filter housings are designed to withstand pressure surges as well as high static pressure loads.
- The screw-in bowl allows the filter element to be easily removed for replacement or cleaning.
- Visual (pop-up), electrical, electrical/visual (lamp), or electronic differential type clogging indicators can be installed.
- DF...QE filters are available with or without a bypass valve so either high or low collapse pressure elements may be used.
- Fatigue pressure rating equals maximum allowable working pressure rating.

Technical Details

| | | |
|---|--|--------------------|
| Mounting Method | 4 mounting holes (<i>manifold mount</i>) | |
| Port Connection | Diameters | |
| 30 | 0.551" (14mm) | |
| 60/110 | 0.787" (20mm) | |
| 160/240/280 | 1.260" (32mm) | |
| 330/660/1320 | 1.181" (30mm) | |
| Flow Direction | Inlet: Side | Outlet: Side |
| Construction Materials | | |
| Head | Ductile iron | |
| Bowl | Steel | |
| Housing (1320) | Steel | |
| Cap (1320) | Ductile iron | |
| Flow Capacity | | |
| 30 | 8 gpm (30 lpm) | |
| 60 | 16 gpm (60 lpm) | |
| 110 | 29 gpm (110 lpm) | |
| 160 | 42 gpm (160 lpm) | |
| 240 | 63 gpm (240 lpm) | |
| 280 | 74 gpm (280 lpm) | |
| 330 | 87 gpm (330 lpm) | |
| 660 | 174 gpm (660 lpm) | |
| 1320 | 180 gpm (1320 lpm) | |
| Housing Pressure Rating | QE | MHE |
| Max. Operating Pressure | 4500 psi (315 bar) | 3625 psi (250 bar) |
| Proof Pressure | 6750 psi (472 bar) | 5438 psi (375 bar) |
| Fatigue Pressure | 4500 psi (315 bar) | 3625 psi (250 bar) |
| | @ 1 mil. cycles | @ 100 mil. cycles |
| Burst Pressure | Contact HYDAC | |
| Element Collapse Pressure Rating | | |
| BH/HC, V | 3045 psid (210 bar) | |
| BN/HC, W/HC | 290 psid (20 bar) | |
| Fluid Temperature Range | -22° to 250°F (-30° to 121°C) | |
| Fluid Compatibility | | |
| Compatible with all petroleum oils and synthetic fluids rated for use with Fluoroelastomer or Ethylene Propylene seals. Contact HYDAC for information on special housing and element constructions available for use with water glycols, oil/water emulsions, and HWBF. | | |
| Indicator Trip Pressure | | |
| ΔP = 29 psid (2 bar) -10% (<i>optional</i>) | | |
| ΔP = 72 psid (5 bar) -10% (<i>standard</i>) | | |
| Bypass Valve Cracking Pressure | | |
| ΔP = 43 psid (3 bar) +10% (<i>optional</i>) | | |
| ΔP = 87 psid (6 bar) +10% (<i>standard</i>) | | |

Applications



Industrial



Railways



Steel / Heavy Industry

Model Code

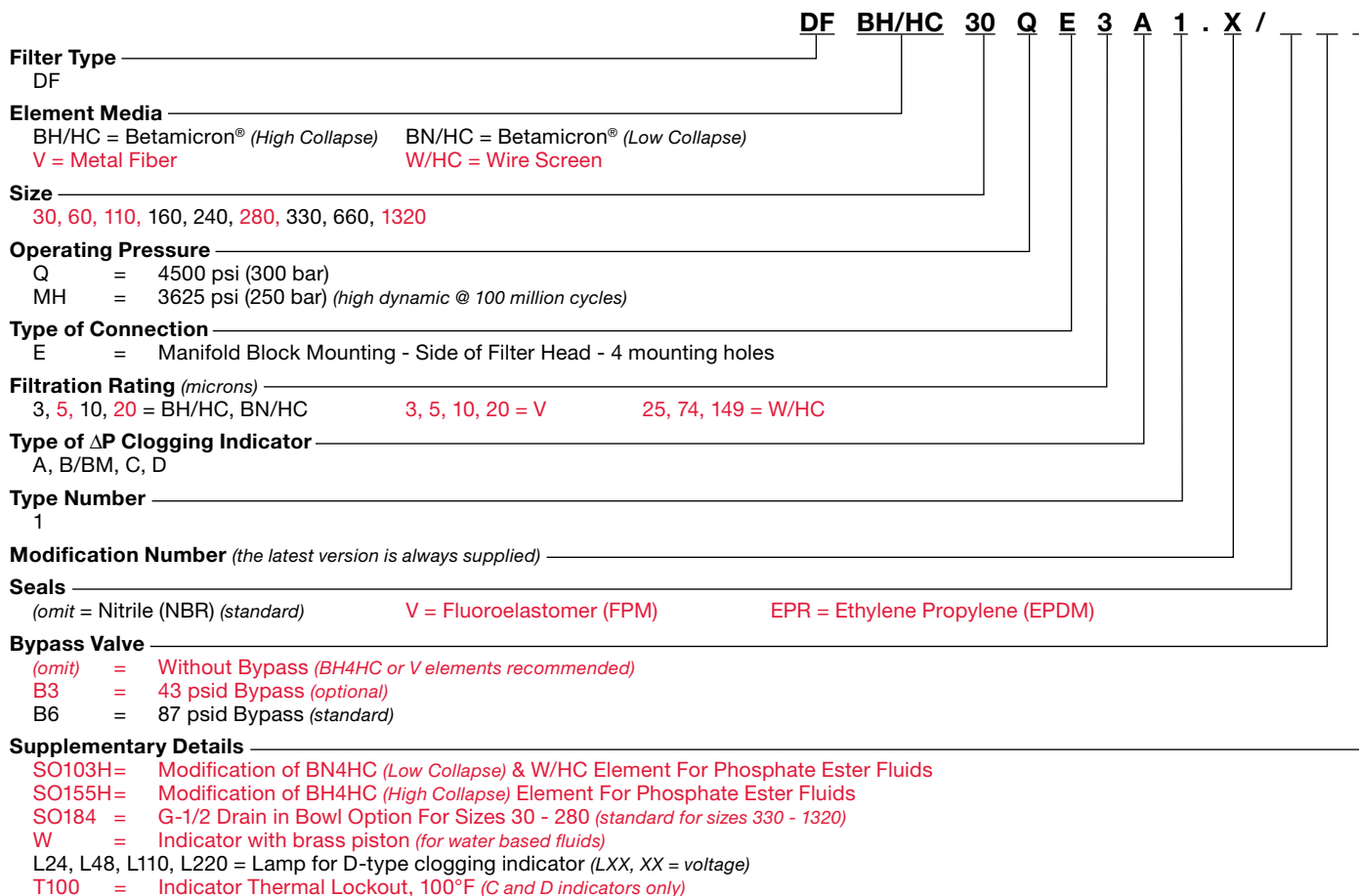

Replacement Element Model Code

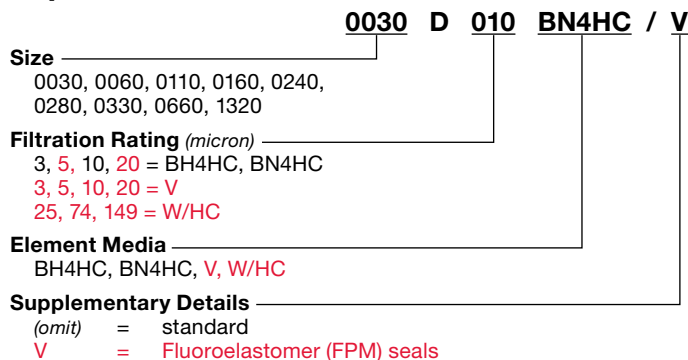

Clogging Indicator Model Code

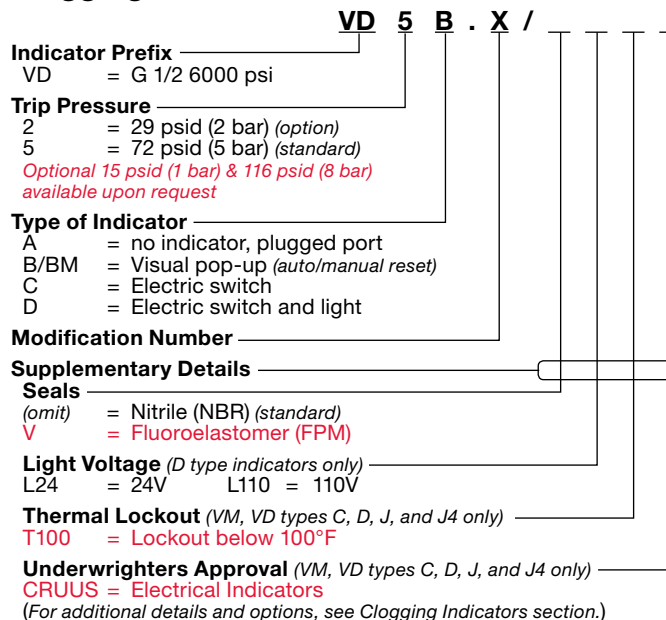

Model Codes Containing RED are non-stock items — Minimum quantities may apply — Contact HYDAC for information and availability

Dimensions

DF 30 – 280 QE

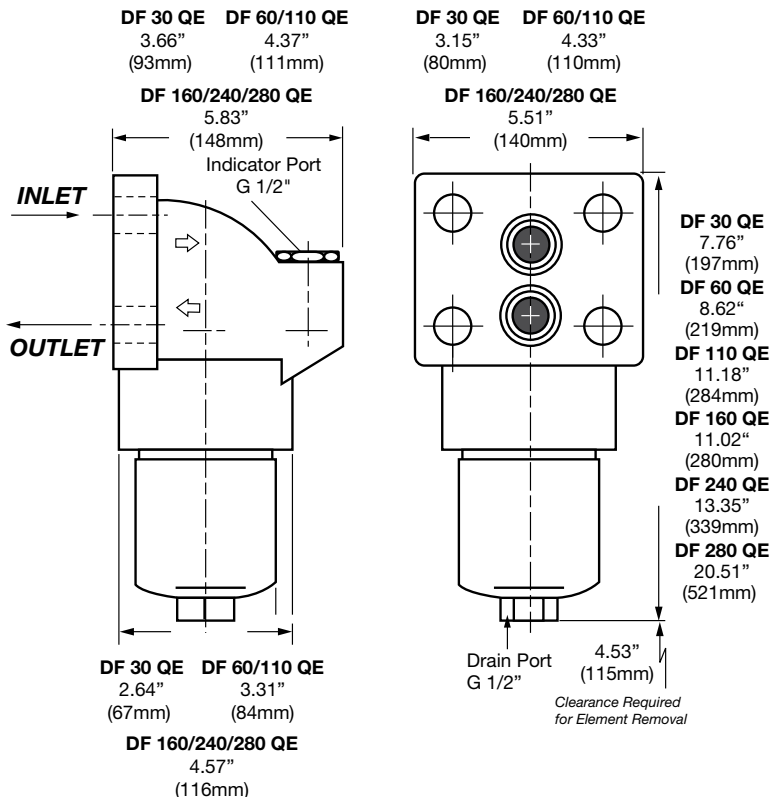

Mounting Pattern

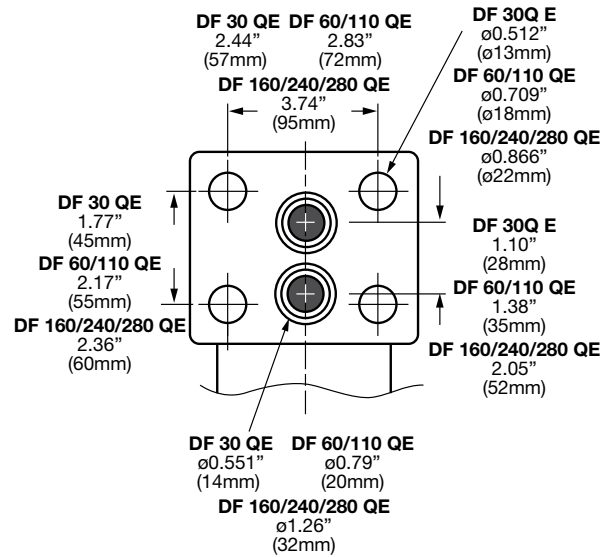

DF 330 – 660 QE

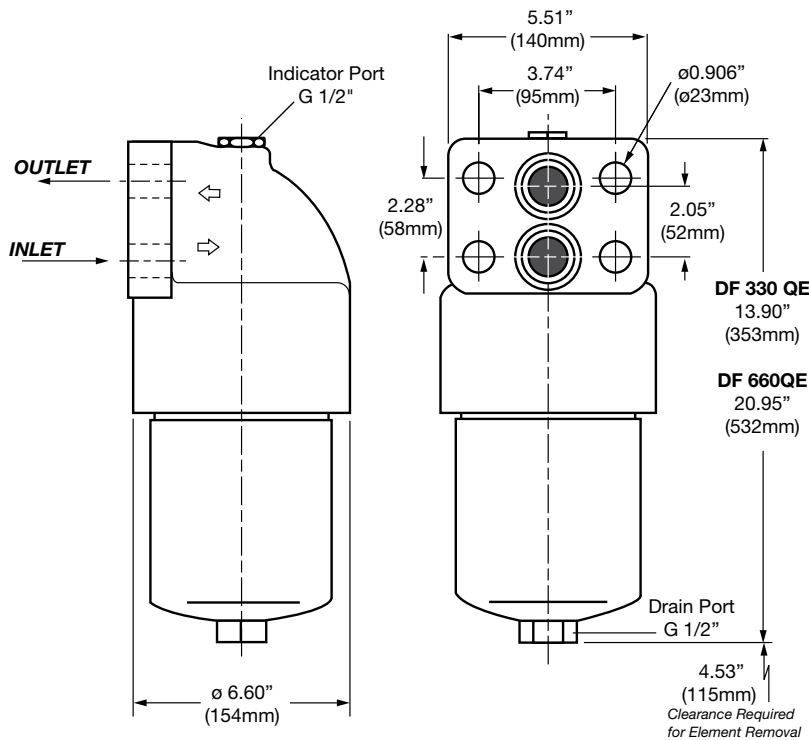

DF 1320 QE

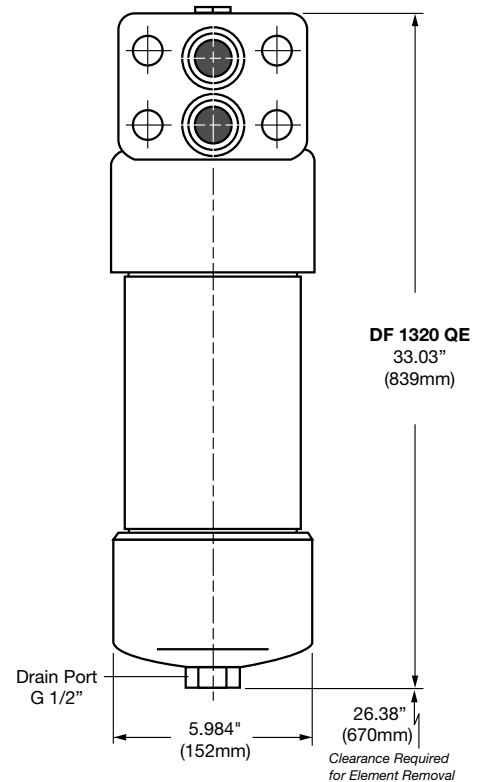

| Size | 30 | 60 | 110 | 160 | 240 | 280 | 330 | 660 | 1320 |
|---------------|-----|------|------|------|------|------|------|------|-------|
| Weight (lbs.) | 6.0 | 10.8 | 12.8 | 20.0 | 22.7 | 31.9 | 47.8 | 63.2 | 105.8 |

Dimensions shown are for general information and overall envelope size only. Weights listed are without element. For complete dimensions please contact HYDAC to request a certified print.

Sizing Information

Total pressure loss through the filter is as follows:

$$\text{Assembly } \Delta P = \text{Housing } \Delta P + \text{Element } \Delta P$$

Housing Curve:

Pressure loss through housing is as follows:

$$\text{Housing } \Delta P = \text{Housing Curve } \Delta P \times \frac{\text{Actual Specific Gravity}}{0.86}$$

Adjustments must be made for viscosity & specific gravity of the fluid to be used! (see sizing section on page 19)

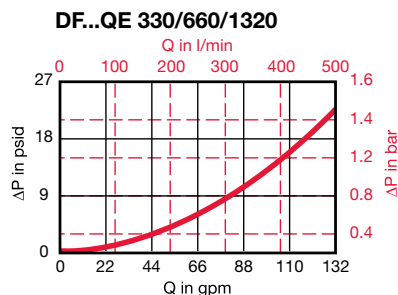
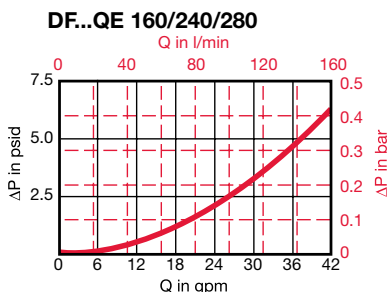
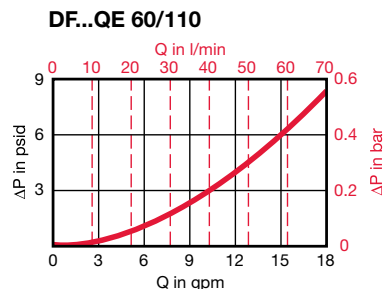
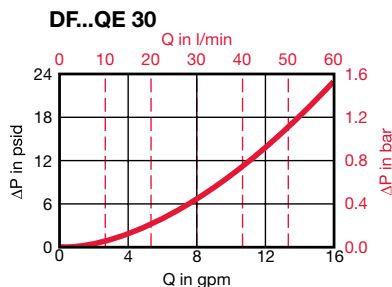

Element K Factors

$$\Delta P \text{ Elements} = \text{Elements (K) Flow Factor} \times \text{Flow Rate (gpm)} \times \frac{\text{Actual Viscosity (SUS)}}{141 \text{ SUS}} \times \frac{\text{Actual Specific Gravity}}{0.86}$$

(From Tables Below)

| Size | ...D...BN4HC (Betamicon® Low Collapse) | | | |
|------|--|-------|-------|-------|
| | 3 μm | 5 μm | 10 μm | 20 μm |
| 0030 | 3.504 | 2.374 | 1.251 | 0.618 |
| 0060 | 1.582 | 1.116 | 0.723 | 0.433 |
| 0110 | 0.819 | 0.585 | 0.361 | 0.205 |
| 0140 | 0.701 | 0.450 | 0.261 | 0.157 |
| 0160 | 0.718 | 0.480 | 0.252 | 0.193 |
| 0240 | 0.450 | 0.333 | 0.196 | 0.128 |
| 0280 | 0.220 | 0.171 | 0.092 | 0.071 |
| 0330 | 0.294 | 0.215 | 0.163 | 0.095 |
| 0660 | 0.136 | 0.099 | 0.061 | 0.044 |
| 1320 | 0.068 | 0.048 | 0.030 | 0.021 |

| Size | ...D...BH4HC (Betamicon® High Collapse) | | | |
|------|---|-------|-------|-------|
| | 3 μm | 5 μm | 10 μm | 20 μm |
| 0030 | 5.000 | 2.780 | 1.989 | 1.042 |
| 0060 | 3.210 | 1.785 | 0.993 | 0.669 |
| 0110 | 1.394 | 0.819 | 0.488 | 0.307 |
| 0160 | 0.919 | 0.569 | 0.322 | 0.240 |
| 0240 | 0.578 | 0.374 | 0.214 | 0.158 |
| 0280 | 0.313 | 0.184 | 0.097 | 0.090 |
| 0330 | 0.422 | 0.244 | 0.154 | 0.108 |
| 0660 | 0.179 | 0.106 | 0.055 | 0.049 |
| 1320 | 0.089 | 0.054 | 0.031 | 0.024 |

| Size | ...D...V Elements | | | |
|------|-------------------|-------|-------|-------|
| | 3 μm | 5 μm | 10 μm | 20 μm |
| 0030 | 1.011 | 0.740 | 0.411 | 0.200 |
| 0060 | 0.877 | 0.511 | 0.296 | 0.183 |
| 0110 | 0.452 | 0.304 | 0.182 | 0.118 |
| 0160 | 0.251 | 0.177 | 0.123 | 0.079 |
| 0240 | 0.169 | 0.137 | 0.093 | 0.062 |
| 0280 | 0.126 | 0.093 | 0.064 | 0.041 |
| 0330 | 0.121 | 0.097 | 0.065 | 0.043 |
| 0660 | 0.063 | 0.050 | 0.034 | 0.021 |
| 1320 | 0.032 | 0.026 | 0.018 | 0.012 |

| Size | ...D...W/HC Elements |
|------|------------------------------|
| | 25, 50, 74, 100, 149, 200 μm |
| 0030 | 0.185 |
| 0060 | 0.092 |
| 0110 | 0.050 |
| 0160 | 0.035 |
| 0240 | 0.023 |
| 0280 | 0.020 |
| 0330 | 0.020 |
| 0660 | 0.008 |
| 0990 | 0.006 |

All Element K Factors in psi / gpm.