

RFL Casted Series Inline Filters

360 PSI • up to 350 GPM

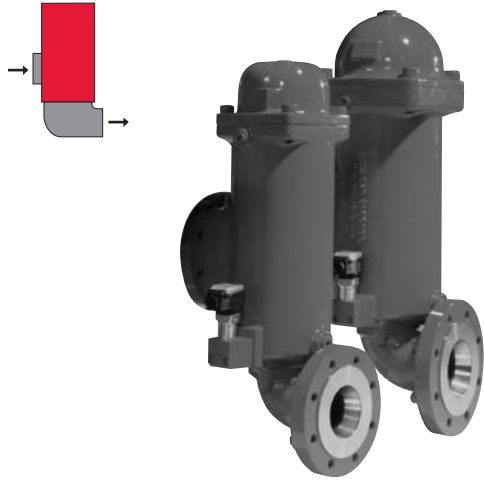

Hydraulic Symbol

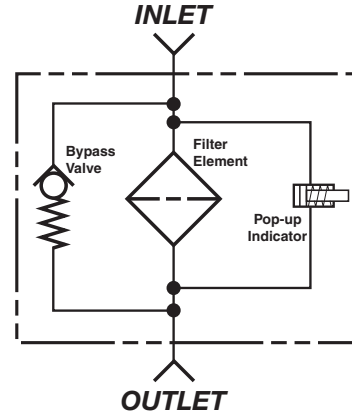

Features

- Models 851 and 1301 are made of ductile cast iron and consist of a two part filter housing with bolt-on cast iron lid. The two part construction makes it possible to arrange the inlet and outlet either one above the other on one side or, by turning the base part 180°, on opposite sides of the housing.
- Inlet/outlet ports for models 851 and 1301 comply with SAE 4-bolt flange Code 61 configuration.
- Clogging indicators have no external dynamic seal. High reliability is achieved and magnetic actuation eliminates a leak point.

Technical Details

Mounting Method	Support by means of pipe clamps
Port Connection	851 SAE-48 Flange, Code 61 1301 SAE-64 Flange, Code 61
Flow Direction	Inlet: Side Outlet: Side
Construction Materials	Head, Lid, Elbow Ductile iron
Flow Capacity	851 225 gpm (850 lpm) 1301 343 gpm (1300 lpm)
Housing Pressure Rating	Max. Operating Pressure 360 psi (25 bar) Proof Pressure 540 psi (38 bar) Fatigue Pressure 360 psi (25 bar) Burst Pressure > 1440 psi (100 bar)
Element Collapse Pressure Rating	BN/HC, W/HC 250 psid (17 bar) ECO/N, BN/AM, P/HC, AM 145 psid (10 bar)
Fluid Temperature Range	-22° to 250°F (-30° to 121°C)
Fluid Compatability	Compatible with all petroleum oils and synthetic fluids rated for use with Fluoroelastomer or Ethylene Propylene seals. Contact HYDAC for information on special housing and element constructions available for use with water glycols, oil/water emulsions, and HWBF.
Indicator Trip Pressure	$\Delta P = 29$ psid (2 bar) -10% $\Delta P = 72$ psid (5 bar) -10%
Bypass Valve Cracking Pressure	$\Delta P = 43$ psid (3 bar) +10% $\Delta P = 87$ psid (6 bar) +10%

Applications



Automotive



Gearboxes



Industrial



Power
Generation

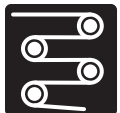

Pulp & Paper



Shipbuilding



Steel / Heavy
Industry

Model Code

RFL BN/HC 851 F 3 A 1 . X / 16 V

Filter Type _____
 RFL = Inline Filter

Element Media _____
 BN/HC = Betamicon® (Low Collapse) ECO/N = ECOMicon® (Low Collapse)
 AM = Aquamicon® BN/AM = Betamicon®/Aquamicon®
 P/HC = Polyester W/HC = Wire Screen

Size _____
 851 = 3" inlet & outlet with 1 (0850R) element
 1301 = 4" inlet & outlet with 1 (1300R) element

Type of Connection _____
 F = flange connection

Filtration Rating (microns) _____
 3, 5, 10, 20 = BN/HC, ECO/N 3, 10 = BN/AM 40 = AM
 10, 20, = P/HC 25, 74, 149 = W/HC

Type of ΔP Clogging Indicator _____

A	= no indicator	Indicator Model
B	= visual (auto-reset)	VM...B
C	= electric switch	VM...C
D	= electric switch and light	VM...D/L

 (For details and additional indicator options, see pages 201 - 230)

Type Code _____
 1

Modification Number (latest version always supplied) _____

Connection _____
 16 = SAE flange

Seals _____
 (omit) = Buna N (NBR)(standard)
 V = Fluoroelastomer (FPM)
 EPR = Ethylene Propylene (EPDM)

Bypass Valve Cracking Pressure _____
 (omit) = 43 psid (3 bar) (return line - standard)
 KB = no bypass (flushing system)
 B6 = 87 psid (6 bar) (return line - extended service life)] not available with ECO/N
 B1 = 15 psid (1 bar) (lubrication or coolant application)
 B0.2 = 3 psid (0.2 bar) (pump inlet)

Supplementary _____
 W = Indicator with brass piston (for water base fluids)
 SO103H = Modification of BN4HC Elements for Phosphate Ester Fluids

Replacement Element Model Code

0850 R 010 BN4HC / V

Size _____
 0850, 1300

Filtration Rating (micron) _____
 3, 5, 10, 20 = BN4HC, ECO/N 3, 10 = BN/AM 40 = AM
 10, 20, = P/HC 25, 74, 149 = W/HC

Element Media _____
 BN4HC, ECO/N, BN/AM, AM, P/HC, W/HC

Supplementary Details _____
 (omit) = standard
 V = Fluoroelastomer (FPM) seals

Model Codes Containing RED are non-stock items — Minimum quantities may apply – Contact HYDAC for information and availability

HYDAC Low Pressure Filters

Dimensions

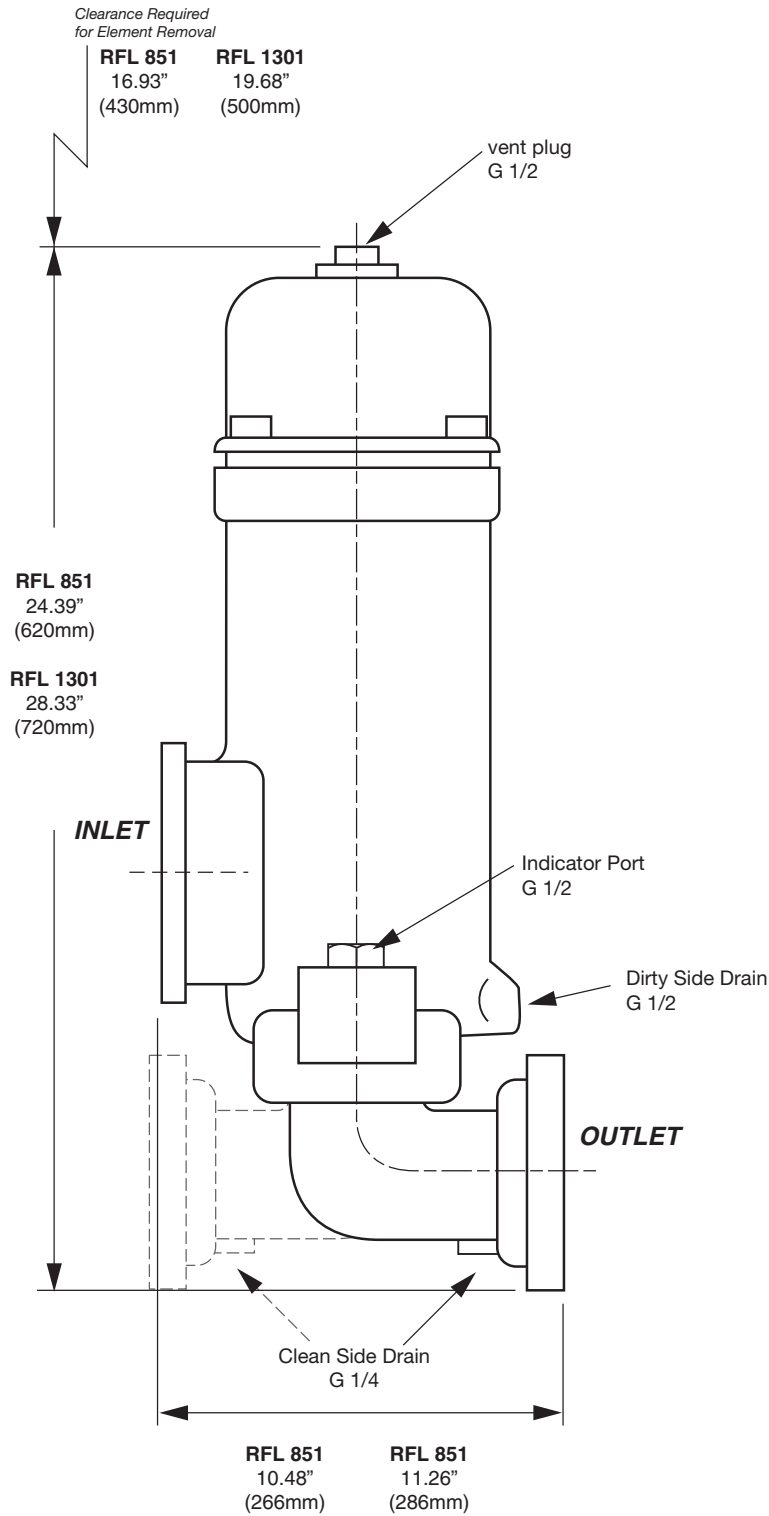

Size	851	1301
Weight (lbs.)	5.1	10.4

Dimensions shown are for general information and overall envelope size only. Weights listed are without element. For complete dimensions please contact HYDAC to request a certified print.

Sizing Information

Total pressure loss through the filter is as follows:

Assembly $\Delta P = \text{Housing } \Delta P + \text{Element } \Delta P$

Housing Curve:

Pressure loss through housing is as follows:

Housing $\Delta P = \text{Housing Curve } \Delta P \times \frac{\text{Actual Specific Gravity}}{0.86}$

Adjustments must be made for viscosity & specific gravity of the fluid to be used! (see sizing section on page 21)

RFL 851 HOUSING

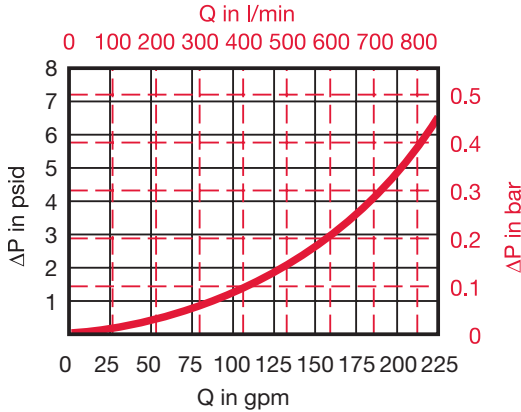

RFL 1301 HOUSING

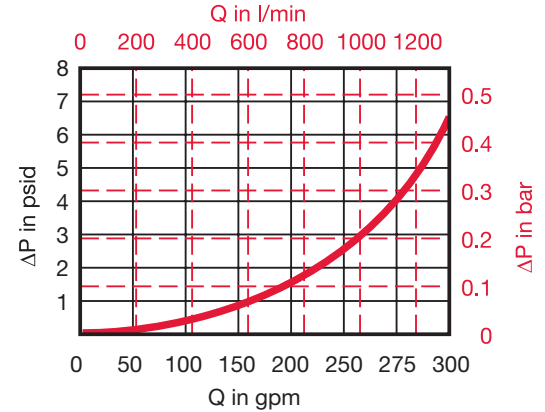

Element K Factors

$\Delta P \text{ Elements} = \text{Elements (K) Flow Factor} \times \text{Flow Rate (gpm)} \times \frac{\text{Actual Viscosity (SUS)}}{141 \text{ SUS}} \times \frac{\text{Actual Specific Gravity}}{0.86}$
(From Tables Below)

Size	...R...BN4HC (Betamicron® Low Collapse)			
	3 μm	5 μm	10 μm	20 μm
0850	0.082	0.055	0.036	0.023
1300	0.045	0.032	0.024	0.014

Size	...R...ECO/N (ECOMICRON®)			
	3 μm	5 μm	10 μm	20 μm
0850	0.078	0.053	0.046	0.032
1300	0.049	0.034	0.029	0.020

Size	...R...P/HC (Polyester)	
	10 μm	20 μm
0850	0.012	0.012
1300	0.007	0.007

Size	...R...W/HC (Wire Screen)
	25, 74, 149 μm
0850	0.0038
1300	0.0027

Size	...R...BN/AM (Betamicron®/Aquamicron®)	
	3 μm	10 μm
1300R	0.088	0.033

All Element K Factors in psi / gpm.