

CSM 2000 Series Contamination Sensor Module

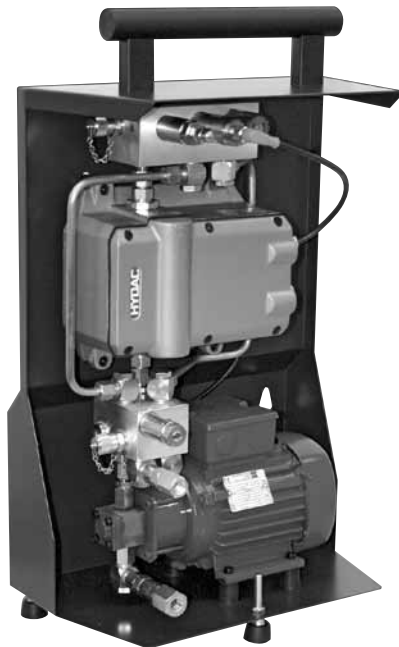

CSM 2000 Installation in Systems

Basically there are four different possibilities for connecting the CSM 2000 to hydraulic and lubrication systems. Select the measuring point according to the type of information the customer requires from the system.

1. Measuring from tank

Indicates the overall condition of the oil. Inlet and outlet of the CSM are connected to the tank near the suction of the main pump.

2. Measuring from the pressure line before the filter

This is the normal location for taking bottle samples. By using the CSM 2000 the amount of bottle sampling can be reduced and information on the oil condition is therefore available immediately. This test point is used mostly in lube systems

3. Measuring from pressure line after the filter

This test point is used in roll hydraulics and the reason for measuring oil after the filter is to ensure that clean oil is always available to the sensitive proportional valves and to other machine parts. Mainly used in roll hydraulics and particularly if customers have had problems with the proportional valves.

Important! The pressure should be reduced using a separate valve before the oil goes into the CSM.

Applications

- Lubrication systems in paper, steel and energy sectors
- Preventive, pro-active preparation of service intervals
- Monitoring of component cleanliness on test benches
- Monitoring of oil cleanliness in storage tanks

Hydraulic Circuit

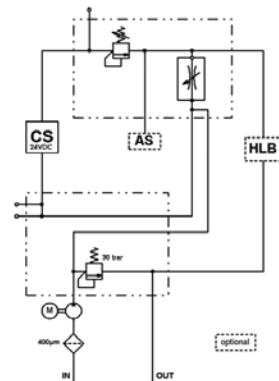

Technical Details

Pump type	Gear pump
Operation pressure	
P_{in} (INLET)	-0.4 to 0.5 bar (standard pump) -0.4 to 120 bar (pump, pressure inlet stable)
P_{out} (OUTLET)	5 bar
P_{out} (leakage line)	0.5 bar (pump, pressure inlet stable)
Permissible outlet pressure	5 bar max
Connections	INLET: Thread G 1/4, ISO 228 OUTLET: Thread G 1/4, ISO 228
Total flow rate	approx. 100 ml/min (standard pump) approx. 180 ml/min (pump, pressure inlet stable)
Permissible operating viscosity range	10 to 3000 cSt
Permissible viscosity range for measuring	10 to 1000 cSt
Permissible Fluid temperature range	32° to 158°F (0° to 70°C)
Permissible fluids	Hydraulic and lubrication fluids based on mineral oil
Power consumption (motor pump group)	0.18 kW @ 50 Hz 0.21 kW @ 60 Hz
Ambient temperature range	32 to 131°F (0° to 55°C)
Storage temperature range	-4 to 185°F (-20 to 85°C)
Relative humidity	max. 90%, not condensing
IP class	IP55
Weight	approx. 40 lbs (18 kg)
ContaminationSensor	
Self-diagnosis	continuously with error indication via status LED
Measuring range	MIN / MAX Display from class ISO 7/6/5 (MIN) up to class ISO 28/27/26 (MAX) Calibrated within the range ISO 13/11/10 to ISO 23/21/18.
Power supply voltage	9 to 36 VDC, residual ripple <10%
Power consumption	3 Watt max
Electrical outputs	- Analog output 4 to 20 mA or 0 to 10 V - RS485 Interface - Switching output

Model Code

Series	CSM	= ContaminationSensor Module
Resolution ContaminationSensor	2	= 4 particle size channels
Contamination Codes	2	= ISO 4406:1999; SAE AS 4059 (D) / > 4 µm(c) > 6 µm(c) > 14 µm(c) > 21 µm(c)
	3	= ISO 4406:1987; NAS 1638 / > 2 µm > 5 µm > 15 µm > 25 µm ISO 4406:1999; SAE AS 4059 (D) / > 4 µm(c) > 6 µm(c) > 14 µm(c) > 21 µm(c) reversible
Contamination Sensor	3	= Standard
Fluids	0	= based on mineral oil
Hydraulic Version	1	= Standard pump
Electrical Output ContaminationSensor	1	= 4 to 20 mA analogue output
	2	= 0 to 10 V analogue output
Supply Voltage Motor Pump Unit	W/N/X60/O60	= 230 V, 50 Hz, 3Ph/ 265 V, 60 Hz, 3Ph, delta connection 400 V, 50 Hz, 3Ph/ 460 V, 60 Hz, 3Ph, star connection
	N/AB/N60/AB60	= 400 V, 50 Hz, 3Ph/ 400 V, 60 Hz, 3Ph, delta connection 690 V, 50 Hz, 3Ph/ 690 V, 60 Hz, 3Ph, star connection
Options	AS	= with AquaSensor AS 1000 Series

Items Supplied:

- CSM
- Operating and Maintenance Instructions
- CD with CoCoS 1000 Software and manuals
- Calibration Certificate ContaminationSensor

Model Codes Containing RED are non-standard items – Minimum quantities and longer lead times may apply - Contact HYDAC for information and availability

Dimensions

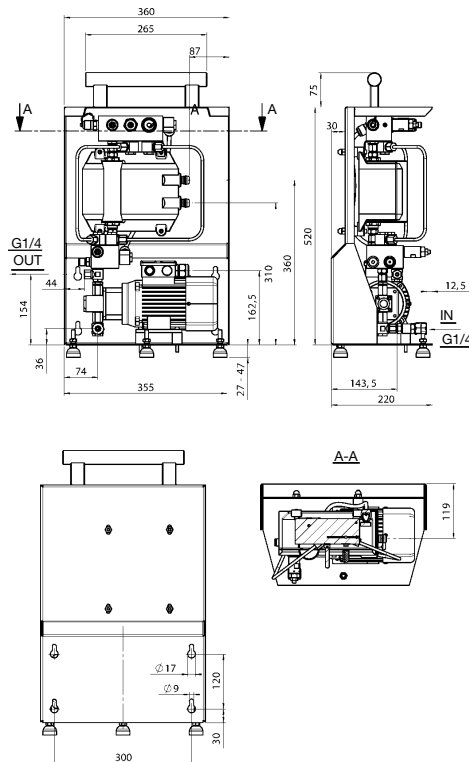

Accessories for:

CS 2000	Part No.
ContaminationControl Software CoCoS 1000	03251484
ContaminationSensor Interface CSI-D-5	03249563
Connector with 2 m cable, screened, 8-pole, M12x1	03281220
Connector with 5 m cable, screened, 8-pole, M12x1	02702459
Extension cable 5 m, socket 8-pole, M12x1 / plug 8-pole, M12x1	03281240
Connector with screw clamp, screened, 8-pole, M12x1	03281243
AS 1000	Part No.
ZBE 08	
Right-angled connector, 5 pole, M12x1	06006786
ZBE 08S-02	
Right-angled connector, with 2 m cable, screened, 5 pole, M12x1	06019455
ZBE 08S-05	
Right-angled connector with 5 m cable, screened, 5 pole, M12x1	06019456
ZBE 08S-10	
Right-angled connector with 10 m cable, screened, 5 pole, M12x1	06023102

Dimensions are millimeters and for general information only, all critical dimensions should be verified by requesting a certified print.