

OFAS & OFAD Series Single & Dual Stage Air-Operated Kidney Loop Systems



OFAS

Description

HYDAC now offers a kidney loop filtration system with a pneumatic motor in place of the standard electric motor. The pneumatic motor offers the same flow capability using the same components, but without the need for an electrical outlet. This provides a major advantage in the application of this unit. With no need for an electrical outlet, it is more portable than the standard electric-motored skids and carts.

Because most trucks and industrial machinery are already equipped with an air compressor, a simple connection to the 1/4" NPT port will easily power the 1.5 HP (or 4.0 HP) motor. At 70 psi, and 2000 rpm, this motor consumes less than 40 cfm (70 cfm for the 4.0HP motor) of compressed air. Because no electricity is used, the pneumatic motor is ideal for working in hazardous environments such as mines.

Applications

- Supplementing in-line filtration by system filters when adequate turnover cannot be attained
- Large volume systems requiring multiple filters in different locations
- Cleaning up a hydraulic system following component replacement
- Ideal location for water removal
- Field applications on service trucks

Technical Details

Flow Rating	7 gpm (26.5 L/min) max and 14 gpm (53.0 L/min) max
Maximum Viscosity	1000 SUS (216 cSt) Higher viscosity version available. Contact factory for details
Maximum Operating Temperature	-20° to 150°F (-29° to 65°C) For higher temperature applications contact factory.
Bypass Valve Setting	Cracking: 30 psi (2 bar)
Material	Manifold and cap: Cast aluminum Element case: Steel
Compatibility	All petroleum based hydraulic fluid. Contact factory for use with other fluids.
Element Change Clearance	9", 18" or 27" (depending on model configuration)

Performance

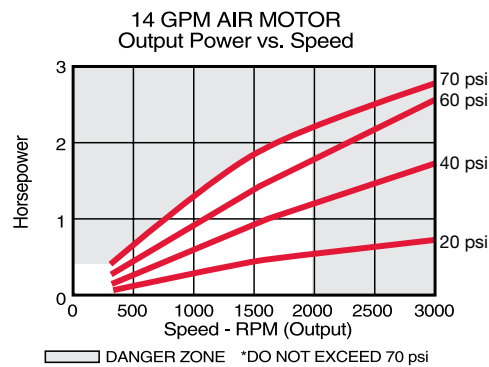
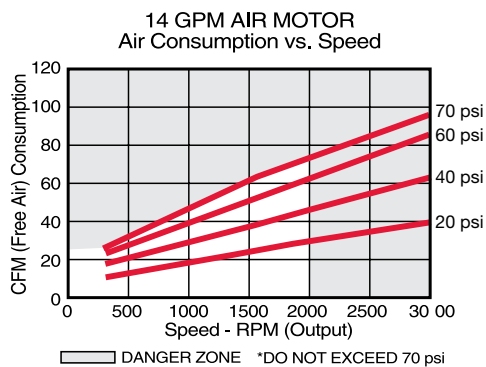
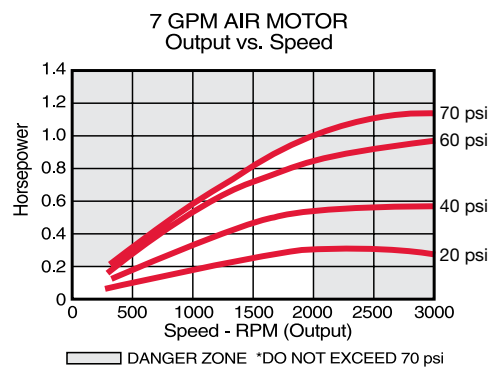
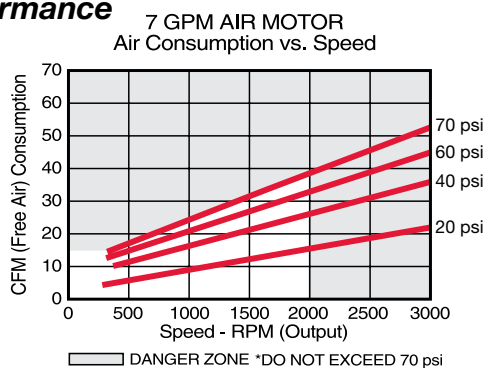

Note: Performance data represents a 4-vane model with no exhaust restriction.

Model Code

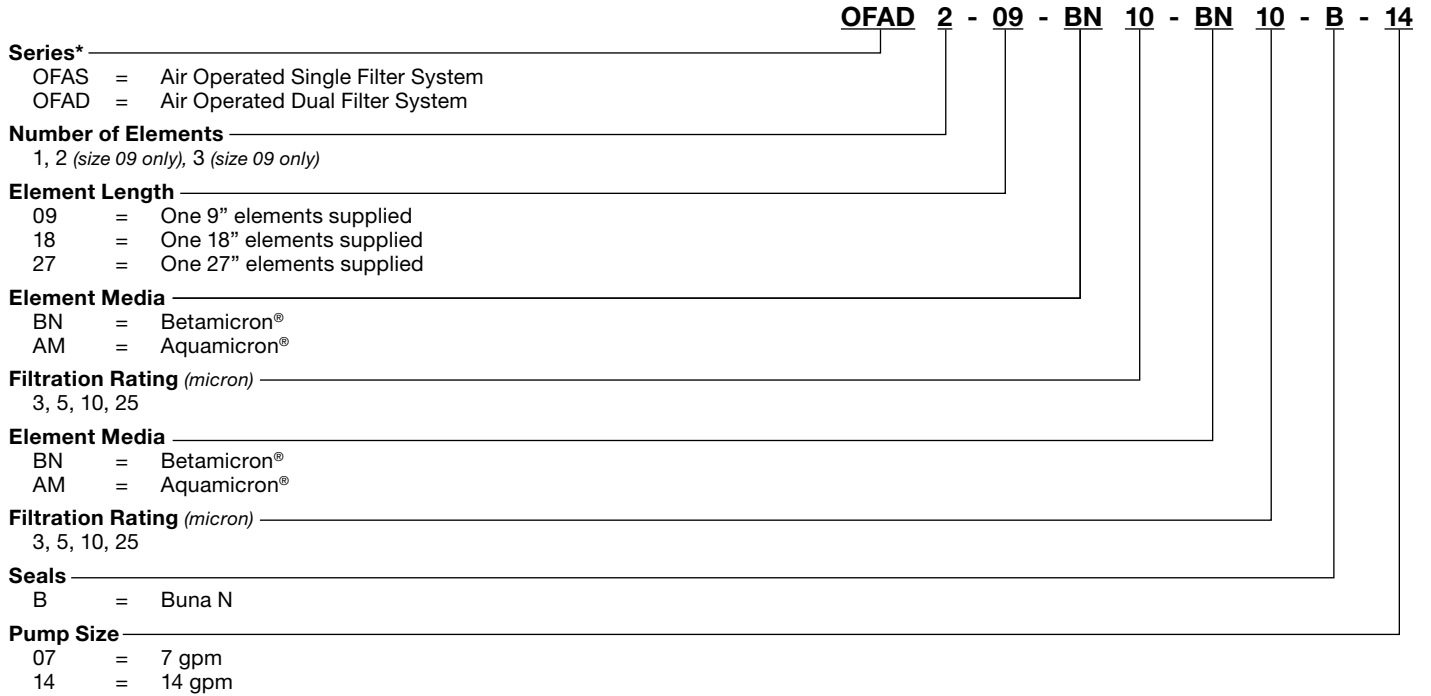

*When OFAS/OFAD is ordered, the number of elements, element length and seals will be identical for both filter housings.

For replacement element part numbers, please see page 69 of this catalog.

Dimensions

OFAS

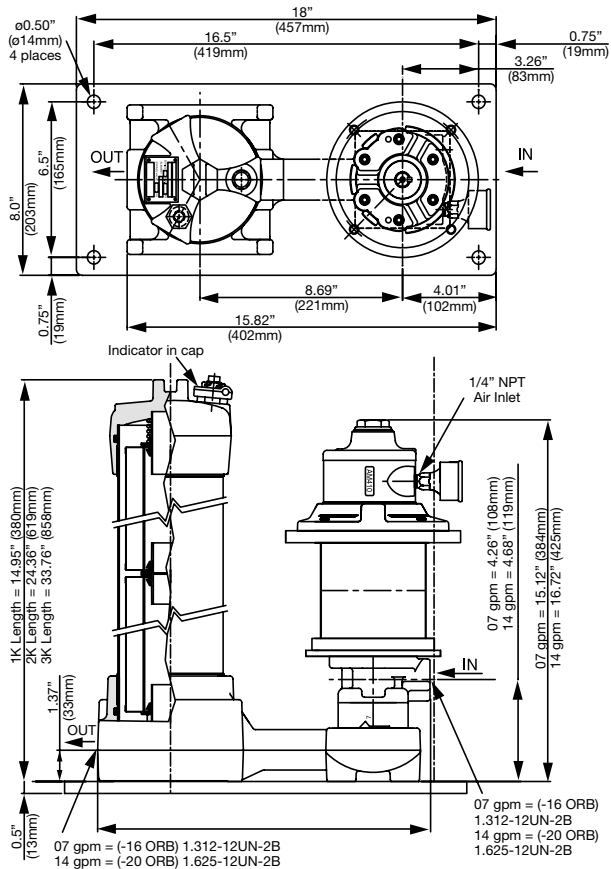

OFAD

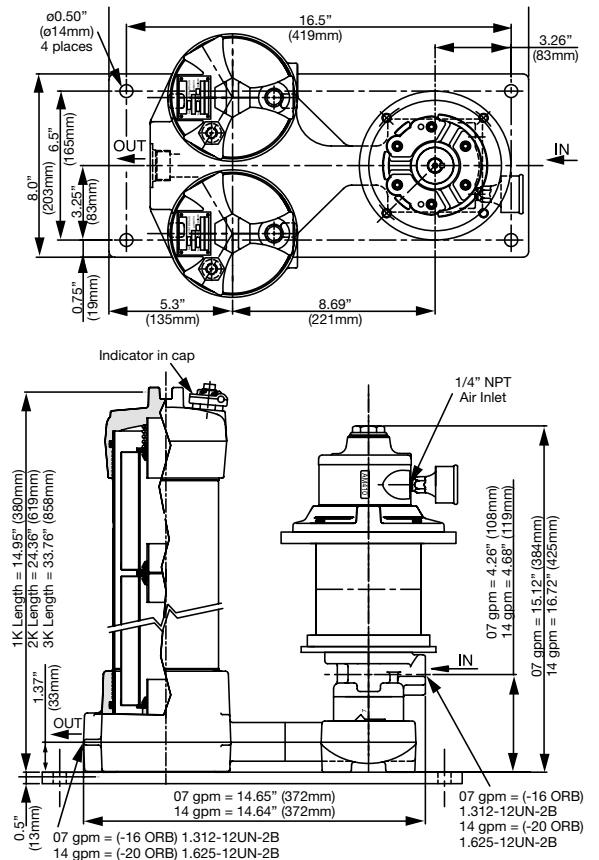

Dimensions are for general information only, all critical dimensions should be verified by requesting a certified print.