

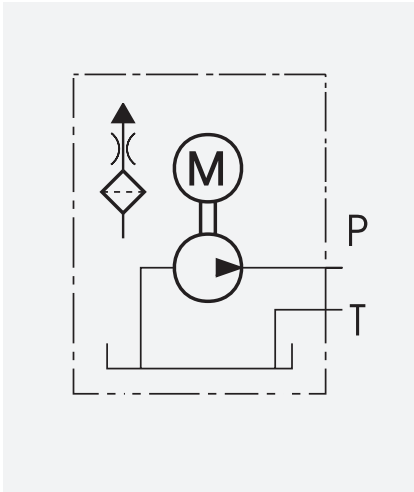

HYDAC "HP" Series high pressure power units are designed to provide a stand alone high pressure hydraulic power source with controls and reservoir all in a rugged modular construction.



Ratings:

- Maximum Pressure: 10,000 PSI
- Maximum Flow: 0.82 GPM
- Short term / Intermittent duty

HP Series High Pressure Power Units

FEATURES

High Pressure

High pressure piston pump elements can provide system pressures to 10,000 psi.

Compact

Pump and motor are internal to the tank. Unit can be portable or installed as an integral part of a new design or existing machine.

Low Noise

Pump and motor are oil-immersed, dampening vibration and noise.

Complete Package

Modular design of controls allows for simple or complex circuit solutions all from one source.

Heavy, Rugged Design

Cast foot housing and thick-walled steel tank provide a tough, yet attractive, power unit.

Global Service & Availability

HYDAC is an international company with world-wide resources to service your needs.

FUNCTION

An electric, oil-immersed motor directly drives a triple element piston pump. Motors with output ranges of 0.38 to 1.50 HP at 1800 RPM are used. This results in an offering of many combinations that can be adapted to specific applications.

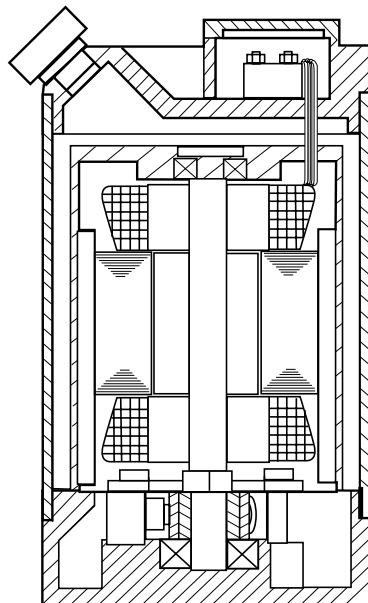

An extensive choice of control packages are available. Standard control blocks and a modular stacking valve system are available. Special customer specific manifolds are built to provide low cost solutions in quantity applications.

HP Series power units are rated for short term (S2) or intermittent (S3) duty. These ratings are detailed in this brochure.

Additional assistance with selection and application of all HYDAC products is available by contacting your local distributor or regional HYDAC sales manager.

Contents

HP Series

applications	4
basic features and function	cover
control valve options	6, 7, 8, 9, 10
dimensions	5
electrical options	11
end plate options	9
HYDAC International locations	back cover
model code and ordering information	2, 3
pressure relief valve	11
special control packages	10
specifications	4

Model Code / Ordering Information

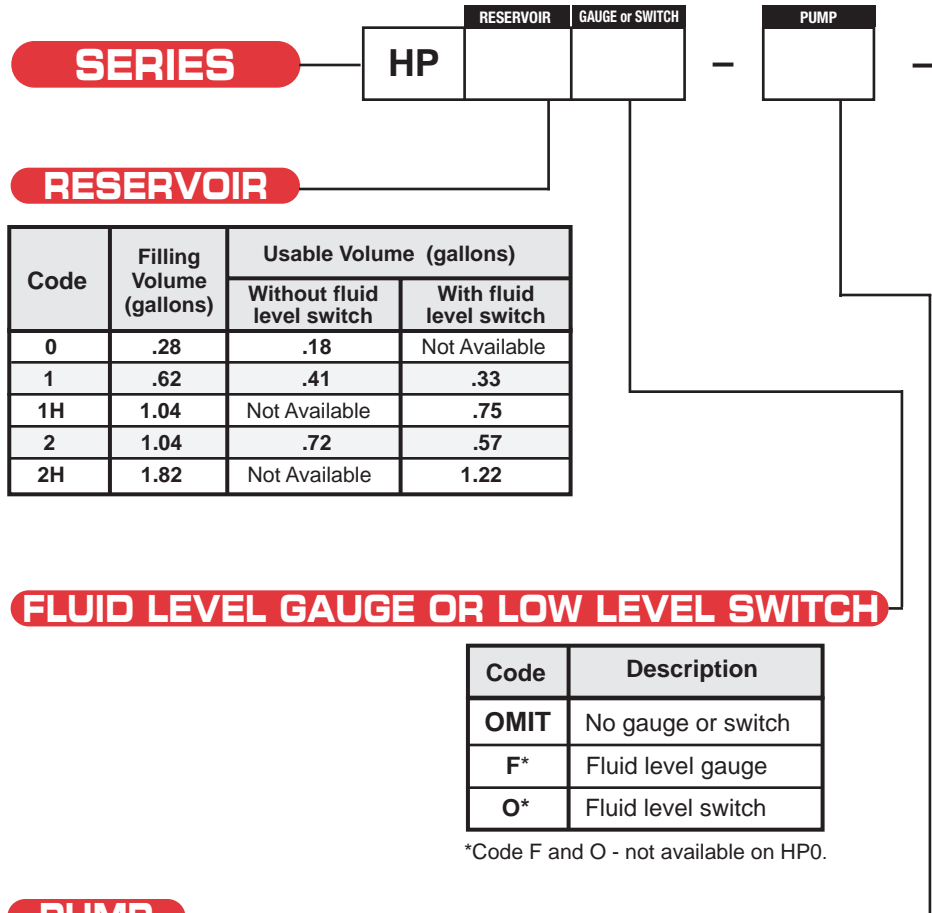

PUMP

HPO							
Code	Flow Rate (GPM)	Single Phase Motor .38 HP			3 Phase Motor .44 HP		
		Pressure (PSI)	Load (AMP)		Pressure (PSI)	Load (AMP)	
			110V	220V		230V	460V
.36	0.09	7900	6.4	3.2	9400	3	1.5
.62	0.16	4700	6.4	3.2	5600	3	1.5
.95	0.24	3000	6.4	3.2	3400	3	1.5
1.50	0.39	1700	7.0	3.5	2300	3	1.5
1.95	0.51	1400	7.0	3.5	1700	3	1.5

HP1/HP1 H							
Code	Flow Rate (GPM)	Single Phase Motor 1.0 HP			3 Phase Motor 1.0 HP		
		Pressure (PSI)	Load (AMP)		Pressure (PSI)	Load (AMP)	
			110V	220V		230V	460V
.60	0.15	10000	11.6	5.8	10000	3.6	1.8
1.00	0.26	6500	11.6	5.8	8700	4.8	2.4
1.50	0.39	4300	11.6	5.8	5500	4.8	2.4
2.40	0.62	2700	11.6	5.8	3600	5.0	2.5
3.15	0.82	1800	11.6	5.8	2600	5.0	2.5

HP2/HP2 H							
Code	Flow Rate (GPM)	Single Phase Motor 1.5 HP			3 Phase Motor 1.5 HP		
		Pressure (PSI)	Load (AMP)		Pressure (PSI)	Load (AMP)	
			110V	220V		230V	460V
.60	0.15	10000	11.6	5.8	10000	3.8	1.9
1.00	0.26	10000	16.6	8.3	10000	5.0	2.5
1.50	0.39	6500	16.2	8.1	6500	5.4	2.7
2.40	0.62	4300	17.4	8.7	5000	6.2	3.1
3.15	0.82	3300	17.4	8.7	3600	6.2	3.1

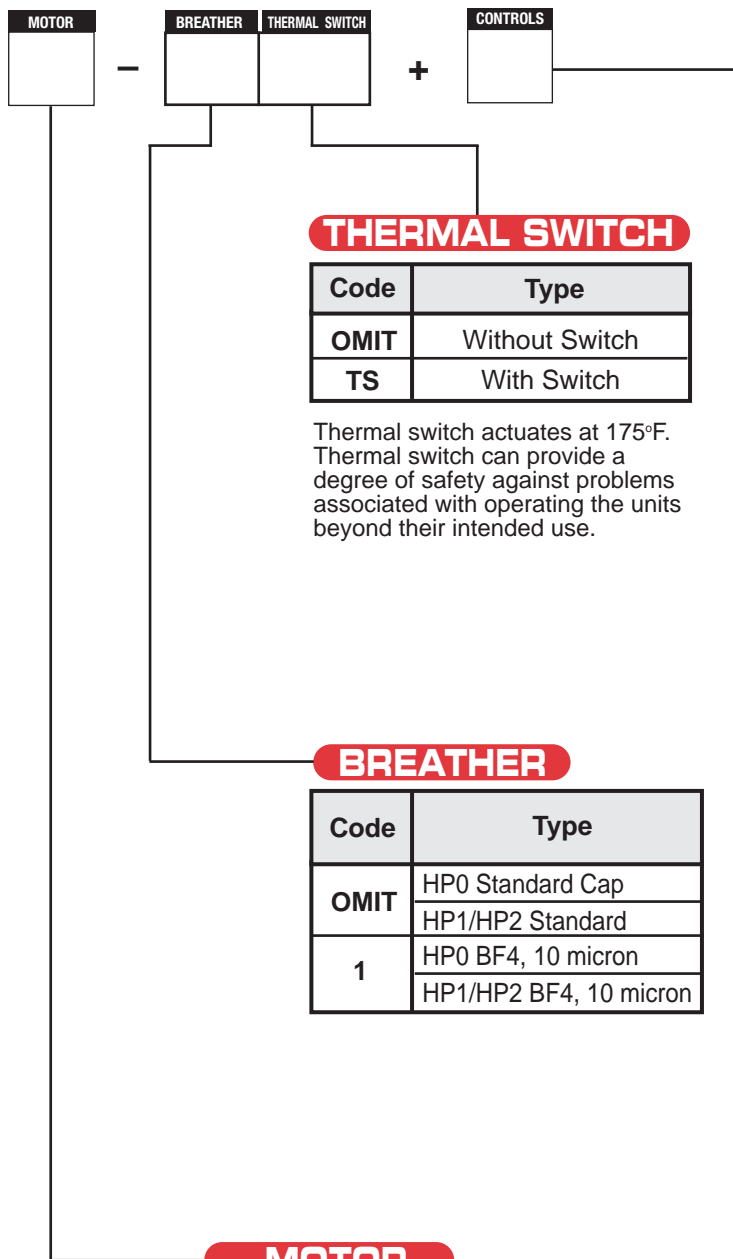

THERMAL SWITCH

Code	Type
OMIT	Without Switch
TS	With Switch

Thermal switch actuates at 175°F. Thermal switch can provide a degree of safety against problems associated with operating the units beyond their intended use.

BREATHER

Code	Type
OMIT	HP0 Standard Cap
	HP1/HP2 Standard
1	HP0 BF4, 10 micron
	HP1/HP2 BF4, 10 micron

MOTOR

HP0

Code	Phase	Voltage
34	Three	230V - 60HZ
36		460V - 60HZ
80	Single	115V - 60HZ
81		220V - 60HZ

HP1/HP1 H

40	Three	220-230/ 440-460V - 60HZ
85	Single	110-115V 220-230V - 60HZ

HP2/HP2 H

40	Three	220-230/ 440-460V - 60HZ
85	Single	110-115V 220-230V - 60HZ

CONTROLS

Modular Construction Allows for a Wide Selection of Control Options

GR

Basic Module includes: relief valve used when no other control values are to be mounted on the unit. See Pg. 6.



SW3

Lifting/Lowering Module mainly for single acting cylinders. See Pg. 7.



SB3

Multi-function module with pressure switch. See Pg. 8.



CER

Build on module with the capability to mount a single station valve with NFPA D03 Interface. See Pg. 8.



CL

Stacking modules designed for multi-station mounting of spool valves with NFPA D03 Interface. See Pg. 9.



L

Base module with relief and check valve to mount "L" series modular stacking valves. See pg. 10.



HP Series

APPLICATIONS



- Machine Tool Clamping
- Special Machines and Fixtures
- Hydraulic Hand Tools, requiring high pressure
- Safety Circuits
- Dental Chairs
- Hospital Beds
- Braking Circuits

DUTY RATINGS

S2 - Short Term Operation

The unit operates for a short period of time, reaching its maximum thermal limit. During time at rest, the unit is allowed time to cool to ambient temperature. This type of operation is usually random, not cyclical.
S2= approximately 5 minutes at full load

S3 - Intermittent Operation

The unit operates in a continuous cycle of run time and idle time. During time at rest, it is not allowed to cool to ambient temperature. However, the unit has cooled sufficiently to allow for the next load cycle without exceeding the thermal limit.
S3= approximately 10% on-time per total cycle

Specifications / Engineering Data

GENERAL

Construction	Triple element piston pump directly driven by an oil immersed AC motor. Steel reservoir and cast foot housing.		
Pressure	Up to 10,000 PSI (700 bar)		
Flow Rate	Up to 0.82 GPM (3.1 LPM)		
Mounting Type	4 mounting holes through the cast foot housing		HP0 0.26" (6.6mm)
			HP1 and HP2 0.35" (9.0mm)
Weight	HP0	17	All weights are without controls or oil.
	HP1/HP1H	30	
	HP2/HP2H	57	
Mounting Position	Unit must be mounted vertically		
Seals	BUNA N		

FLUID SPECIFICATIONS

Operating Fluid	Antiwear type industrial hydraulic oils
Viscosity Range	Minimum : 50 ssu
	Maximum: 3700 ssu
	Optimum : 55 to 925 ssu
Filtration	Maximum permissible contamination : ISO 19/16
Oil Temperature	-4° F to 176° F (-20° C to 80° C)

ELECTRICAL SPECIFICATIONS

Motor	Voltage	3-Phase Motor Single Phase	Please see page 3 for individual motor voltages.
	Amp Draw	See Page 2	
	Connection Type	Terminal strip in terminal box	
	Terminal Box	DIN 40050-IP54	
	Motor Rotation	CW or CCW is acceptable (pump flow internally controlled to the pressure connection)	
Thermal Switch	Actuating Temperature	175° F (80° C)	
	Switchback Hysteresis	20° - 50° F	
	Maximum Voltage	250V AC / 60V DC	
	Contact	Normally closed	
	Connection	In terminal box	
Fluid Level Switch	Contact Load	8 Watts maximum	
	Contact	Opens at minimum oil level	
	Switching Current	.2 Amps	

all models of
HP1 & HP2

HP Series Dimensions

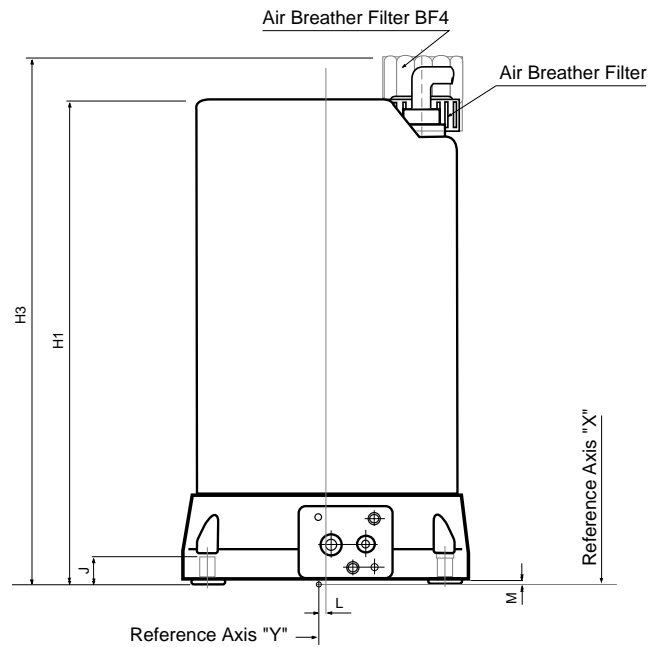
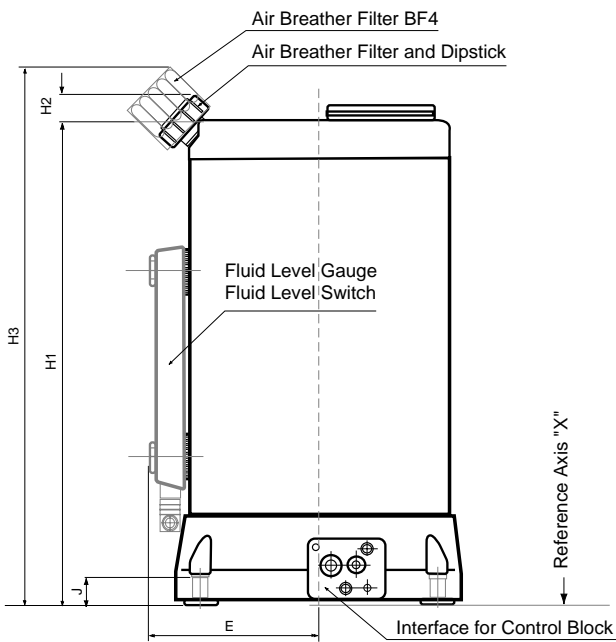
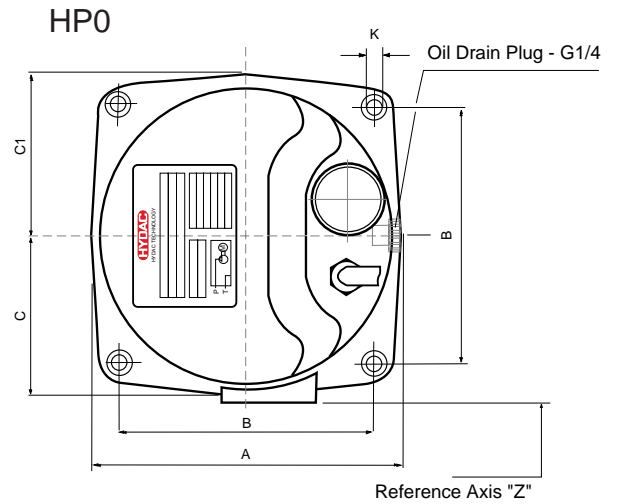
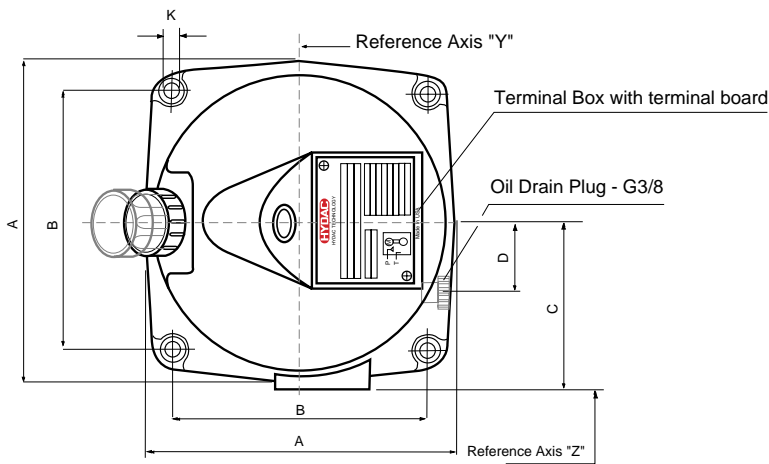

HP SERIES

(inches)

Model	A	B	C	C1	D	E		H1	H2	H3	J	K	L	M
						GAUGE	SWITCH							
HP0	5.12	3.86	2.68	2.56	—	—	—	8.12	—	9.11	.51	.26	.10	.08
HP1	6.46	4.92	3.35	—	1.57	4.21	4.53	11.1	.590	12.4	.59	.35	—	—
HP1 H								15.4		16.7				
HP2	7.48	6.14	3.86	—	1.97	4.61	4.92	12.4	.590	13.8	.59	.35	—	—
HP2 H								17.8		19.1				

(mm)

Model	A	B	C	C1	D	E		H1	H2	H3	J	K	L	M
						GAUGE	SWITCH							
HP0	133	98	68	65	—	—	—	206	—	232	13	6.6	2.5	2
HP1	164	125	85	—	40	107	115	281	15	315	15	9	—	—
HP1 H								390		424				
HP2	190	156	98	—	50	117	125	316	15	350	15	9	—	—
HP2 H								450		484				

Reference lines X, Y and Z are used to calculate installation dimensions when the "L" Series Modular Stacking Valve System is used.

CONTROL TYPE GR



Base module with an integral pressure relief valve and check valve. The unit has SAE O-Ring ports for use with a basic hydraulic circuit when control valves will not be mounted on the power unit.

Control Options

Model Code Example

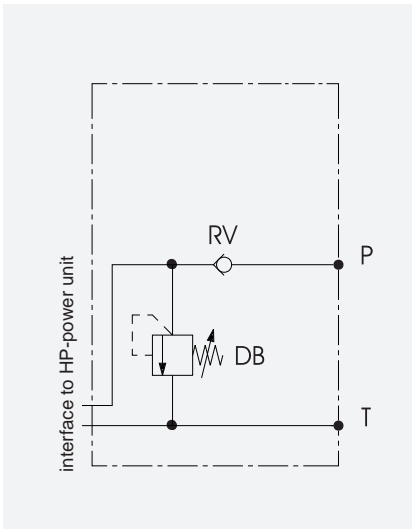
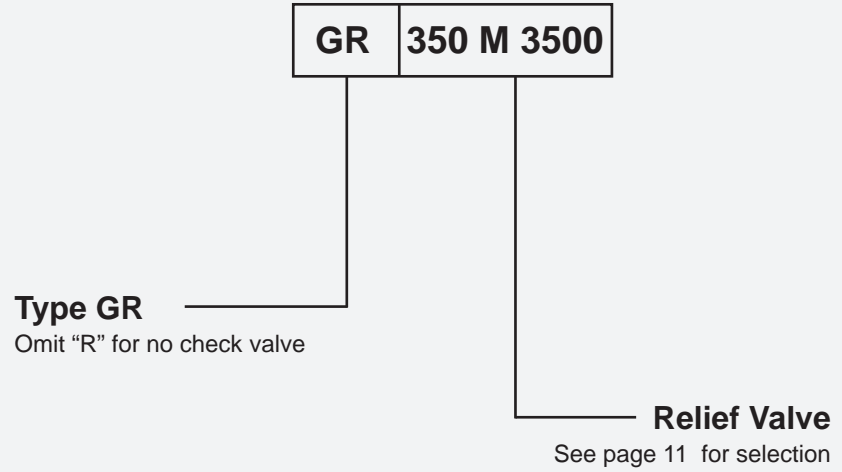

Maximum Pressure = 9000 PSI (630 bar)

Dimensions

in (mm)

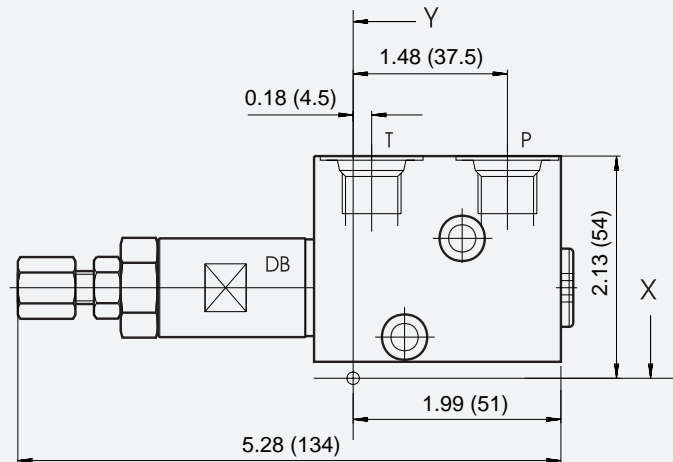

Port T,P = SAE 6
 Installation dimension "Z" : 1.18 (30)

CONTROL TYPE SW3



Lifting-lowering module for controlling single-acting cylinders. Includes relief, check, speed control and 2 position / 2 way solenoid valve.

Control Options

Model Code Example



Type SW3

Solenoid Valve

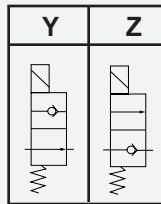

Solenoid Valve
Electrical Options

See page 11

Relief Valve

See page 11 for selection

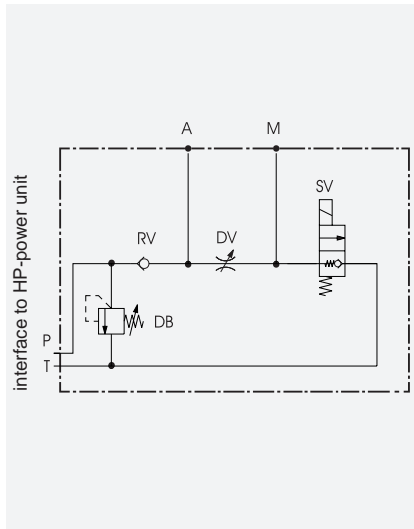

Maximum Pressure = 5000 PSI (350 bar)

Dimensions

in (mm)

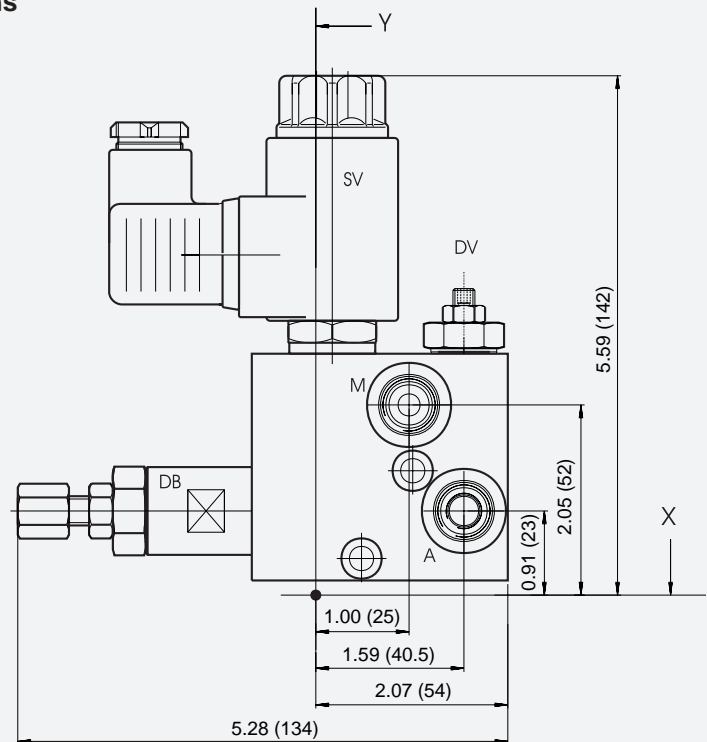

Port A, M = SAE 6

Installation dimension "Z" : 1.69 (43)

CONTROL TYPE SB3



Pressure Control Module for single-acting cylinders. A pressure switch is included.

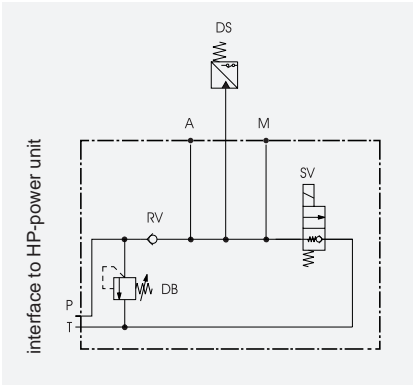

Maximum Pressure = 5000 PSI (350 bar)

Control Options

Model Code Example

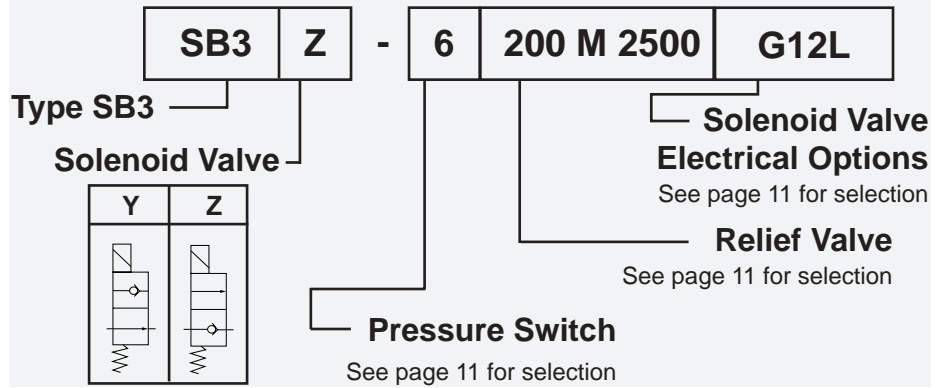

Dimensions

in (mm)

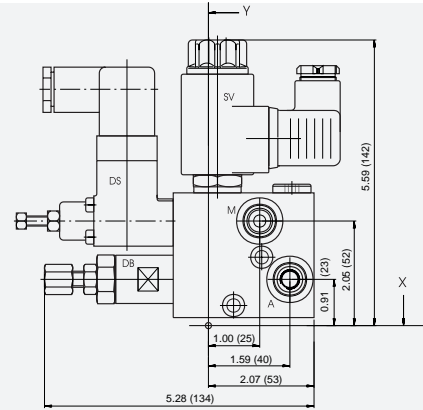

Port A, M = SAE 6
Installation dimension "Z": 1.69 (43)

CONTROL TYPE CER



Base module with pressure relief and check valve. Provides a single-station mounting of an NFPA D03 valve.

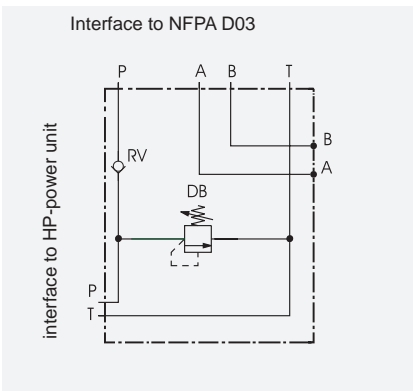

Maximum Pressure = 5000 PSI (350 bar)

Model Code Example

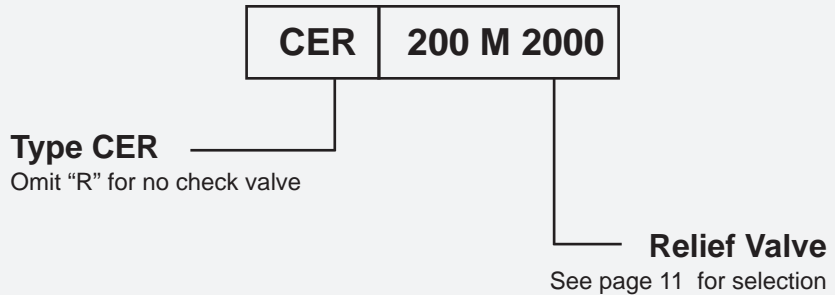

Dimensions

in (mm)

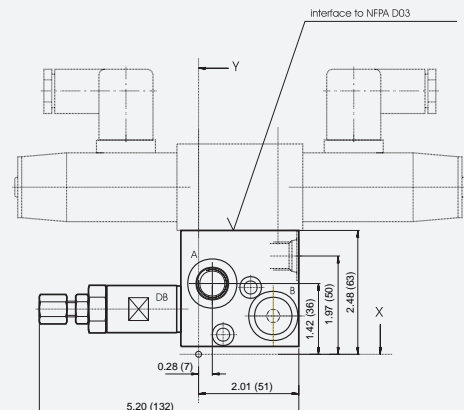

Port A, B = SAE 6
Installation dimension "Z": 2.09 (53)

CONTROL TYPE CL



Provides up to 6 station mounting of NFPA DO3 valves. Basic module has a system relief valve, 2 position/2 way solenoid dump valve and a check valve. The number of stations must be specified, along with an end module for capping the system. The entire system is then fixed with tie rods.

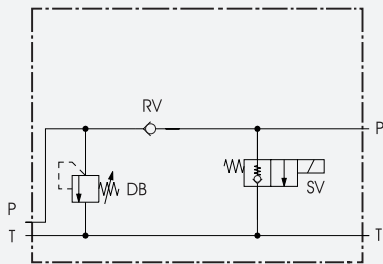

Maximum Pressure = 5000 PSI (350 bar)

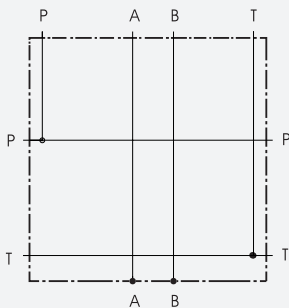

Each stacking module has an NFPA DO3 mounting interface and SAE O-ring ports.

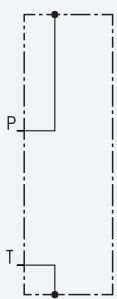

End plate to cap the stack of valves.

Control Options

Model Code Example

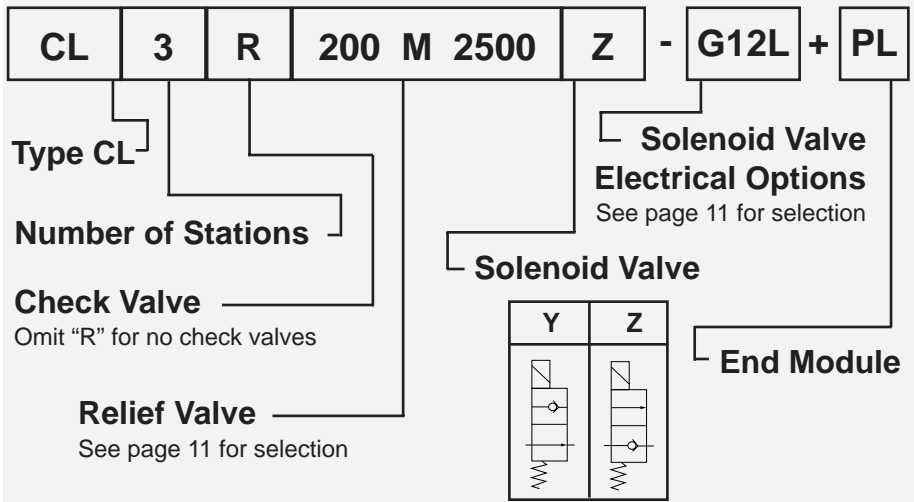

CL Base Model Dimensions

in (mm)

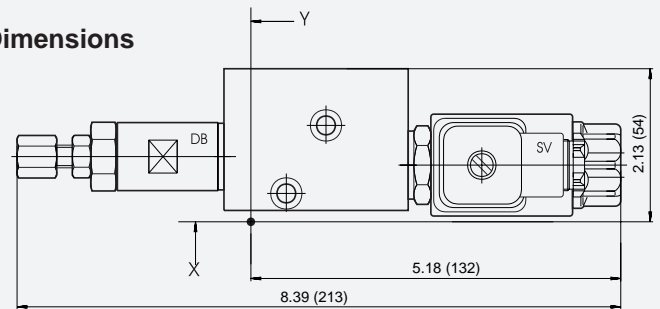

CL Stacking Module Dimensions

in (mm)

interface to NFPA DO3

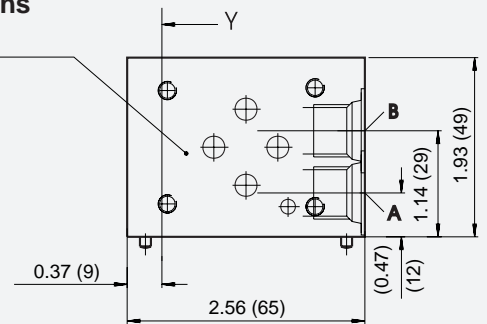

CL End Plate Dimensions

in (mm)

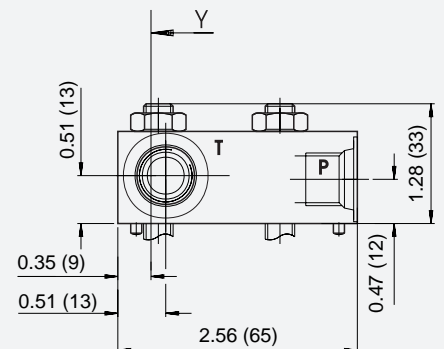

CONTROL TYPE L

Control Type "L" is a modular stacking valve system that offers a variety of cartridge valve control modules that are stacked together to build a working hydraulic circuit. The valve stack is assembled with two tie rods.

Up to 20 modules may be tied together to provide a nearly unlimited amount of unique solutions for simple or complex applications.

Valve modules include a wide variety of pressure and directional controls featuring 100% continuous duty-rated coils and leak-free performance. This system is ideal for clamping and load holding applications.

Control type "L" is detailed in HYDAC Catalog #HHD-L.03/98. A model code selected there can be added to the end of the power unit model code to specify a complete system.

Control Type "L" Application - Sample Circuit

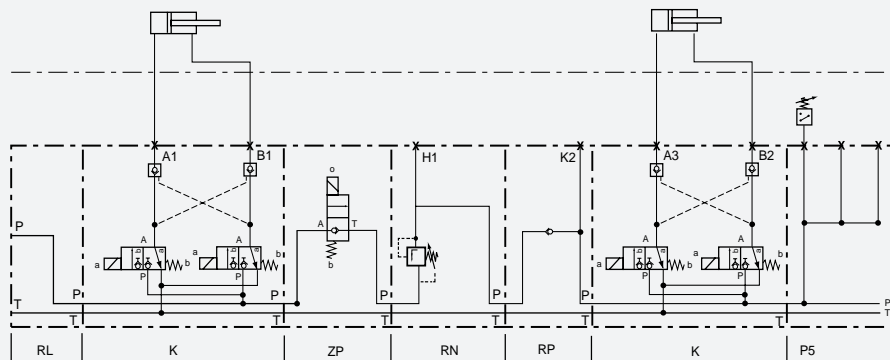

SPECIAL

Customized control packages can be designed and then flange mounted to the hydraulic power unit to meet customer specific needs.

As seen in this catalog, several control options are available. These are designed to handle the most common hydraulic circuits and are produced and supplied as standard components.

Special designs are implemented in situations where our standard module offering does not meet the application needs. Particularly when low cost / high volume requirements are involved; or, when physical size, weight, and appearance are factors.

Please contact your distributor sales representative or HYDAC directly for assistance with Special Controls.

Specially Designed System - Example

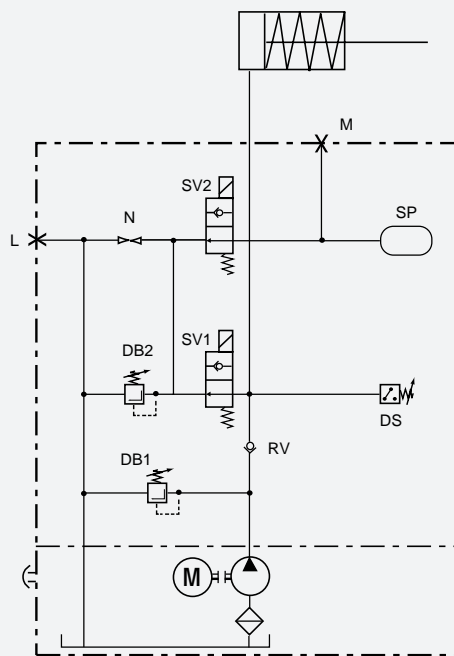

Hydraulic Braking Circuit

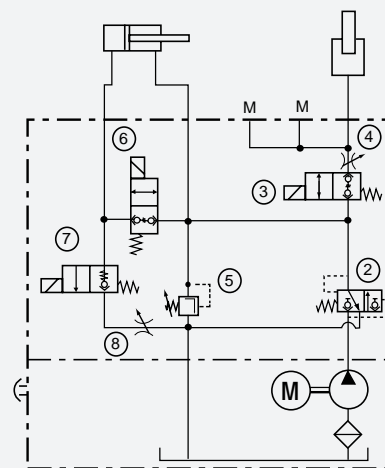

Dock Leveler Circuit

PRESSURE RELIEF VALVE

Dimensions

in (mm)

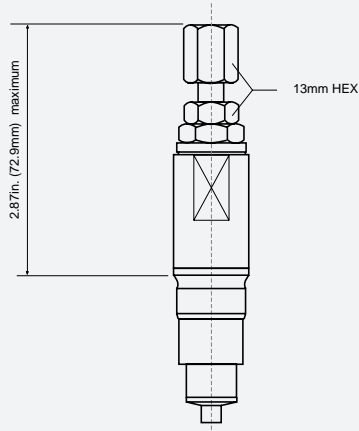

Model Code Example

350 M

3500

Pressure Range

Code	Range
200 M	up to 2900 PSI
350 M	up to 5000 PSI
630 M	up to 9000 PSI

Pre-Set Relieving Pressure

State cracking pressure in PSI.

Omit - valve will be set to maximum pressure capability of the pump/motor combination selected.

ELECTRICAL OPTIONS

Selection Table

Code	Voltage	Connection Type
G12-Z4	12V DC	3-Pin DIN43650-AF2P611
G12L	12V DC	4 inch Flying Leads
G24-Z4	24V DC	3-Pin DIN43650-AF2P611
G24L	24V DC	4 inch Flying Leads
W110-Z4	110V AC	3-Pin DIN43650-AF2P611
W230-Z4	230V AC	3-Pin DIN43650-AF2P611

PRESSURE SWITCH

Dimensions

in (mm)

Connector : DIN43650

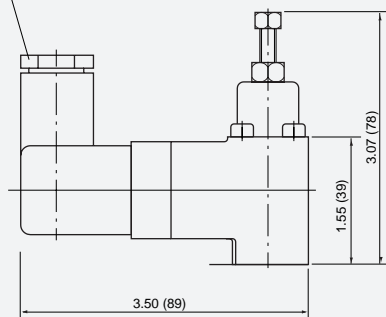

Selection Chart

Code	Adjustment
5	up to 700 PSI
6	up to 2900 PSI
7	up to 5070 PSI
8	up to 9000 PSI

Switch is supplied with electrical connector.

UNITED STATES AND CANADA:

USA
HYDAC Technology Corporation
HYDRAULIC Division
445 Windy Point Drive
Glendale Heights, IL 60139
Tel.: (630) 545-0800
Fax: (630) 545-0033

CANADA
HYDAC Corporation
14 Federal Road
Welland, Ontario
L3B 3P2
Tel.: 905 / 7149322
Fax: 905 / 7144664

FOREIGN COUNTRIES:

AUSTRIA
(Bulgaria, Slovenia, Croatia, Rest of Yugoslavia, Romania)

HYDAC Hydraulik Ges. m.b.H.
Industriestr. 3
A-4066 Pasching
Tel.: 0 72 29 / 6 18 11-0
Fax: 0 72 29 / 6 18 11-35
Teletex: (0 61) 3 73 24 48

AUSTRALIA

HYDAC Pty. Ltd.
111 Dohertys Road
Altona North.
AUS-Vic. 3025
postal address:
P.O. Box 224
Altona North.
AUS-Vic. 3025
Tel.: 3 / 93 69 89 10
Fax: 3 / 93 69 89 12

BRAZIL

HYDAC Limitada
Rua 12 de Outubro, no. 421
CEP 09941-210 - Jd. Canhema
BR-Diadema-SP
Tel./Fax: 011 / 4071-2253

CHILE

MAURICIO HOCHSCHILD S.A.I.C.
Avenida Senador
Jaime Guzman 3535
RCH-Renca-Santiago
Tel.: 2 / 6 41 44 91, 6 41 11 95
Fax: 2 / 6 41 13 23
Telex: 242 565

CHINA

HYDAC Technology (Shanghai) Ltd.
271 Luchun Road
Shanghai Minhang
Economic & Technological
Development Zone
RC-Shanghai 200245
Tel.: 21 / 64633510
Fax: 21 / 64300257

CZECH. REPUBLIC

HYDAC spol. s.r.o.
Chýnovská 535
CZ-39111 Planá nad Luznicí
Tel.: 361 / 891412,
891424,
891570
Fax: 361 / 891270

EGYPT

Yasser Fahmy Hydraulic Eng.
65-66-68 Saudi Building, Kobbba
P.O. Box 6550 Sawah 11813
ET-Cairo
Tel.: 2 / 45 20 192, 45 30 922,
45 30 0923
Fax: 2 / 45 30 638

FINLAND

HYDAC OY
Martinkyläntie 67
FIN-01720 Vantaa
Tel.: 03 58-9 / 8 54 50 50
Fax: 03 58-9 / 85 45 05 20

FRANCE

HYDAC S.à.r.l.
Zone Industrielle du Heid
Rue R. Schumann
F-57350 Stiring-Wendel
Tel.: 03 87 29 26 00
Fax: 03 87 85 90 81

GERMANY

HYDAC
Technology GmbH
Postfach 1251
D-66273 Sulzbach/Saar
Industriegebiet
D-66280 Sulzbach/Saar
Tel.: 0 68 97 / 509-01
Fax: 0 68 97 / 509-454
Telex: 4 429 331

GREAT BRITAIN

HYDAC-FLUPAC Limited
Woodstock Road
GB-Charlbury, Oxfordshire
OX7 3ES
Tel.: 01608 / 811211
Fax: 01608 / 811259
E-Mail: flupac@flupac.co.uk

GREECE

AUTOMATION SYSTEM S.A.
Spirou Patsi 62
GR-11855 Athens
Tel.: 1 / 3 41 16 00
Fax: 1 / 3 42 27 59
Telex: 226892 chat gr

HUNGARY

HYDAC Hidraulika
és Szűrőtechnikai Kft.
Dolmány u. 18-20
H-1131 Budapest
Tel./Fax: 1 / 3 59 93 59

INDIA

HYDAC HYCOM INDIA PVT. Ltd.
114, Mahavir Industrial Estate
Opp. Ravi Industrial Estate
Off Mahakali Caves Road
Andheri (E)
IND-Bombay 400 093
Tel.: 22 / 8386223
Fax: 22 / 8386223

IRAN

Iran Hydraulic Systems Co. Ltd.
310, Mirdamad Ave.
Bazar Bozorg Mirdamad
P.O. Box 19395-3636
IR-Teheran
Tel.: 21 / 8 88 35 18
Fax: 21 / 8 88 90 89
Telex: 213636, Attn. D5067

ITALY

HYDAC S.p.A.
Via Copernico 8
I-20060 Cassina de Pecchi (Mi)
Tel.: 2 / 95 34 30 92
Fax: 2 / 95 34 43 57

JAPAN

HYDAC Co. Ltd.
2-5-12 Kita-Kasai
Edogawa-ku
J-Tokyo
Tel.: 3 / 3804-7060
Fax: 3 / 3804-7062

LUXEMBOURG

FRIEDERICH-HYDROPART
S.A.R.L.
Route d'Esch
C.P. 38
L-3801 Schifflange
Tel.: 54 52 44
Fax: 54 52 48
Telex: 1236 cried lu

MEXICO

Herlo Hidraulica, S.A.
Calzada Vallejo No. 923
Col. Nueva Industrial Vallejo
CP. 07750
MEX-Mexico, D.F.
Tel.: 5 / 567-5400
Fax: 5 / 567-5554

NETHERLANDS

HYDAC B.V.
Postbus 447
NL-5700 AK Helmond
Panovenweg 41
NL-5708 HR Helmond
Tel.: (0) 4 92 / 52 88 38
Fax: (0) 4 92 / 52 75 74

POLAND

HYDAC Sp. z o.o.
ul. Reymonta
PL-43-190 Mikolów
Tel.: 32 / 2 26 26 55
Fax: 32 / 3 26 40 42
Telex: 312981 hydac pl

PORTUGUAL

Gustavo Cudell Lda.
Rua Eng. Ferreira Dias, 954
P-4100 Porto
Tel.: 2 / 6102004
Fax: 2 / 6103070
Telex: 27271

MOVICONTROL LDA
Praca Pedra Verde, 217-222
P-4100 Porto
Tel.: 2 / 6104176
Fax: 2 / 6104475
Telex: 29192 movipo

SINGAPORE

Hydac Technology Pte Ltd.
32 Kallang Pudding Road # 06-05
Elite Industrial Building 1
SGP-Singapore 349313
Tel.: 741 / 7458
Fax: 741 / 0434

SLOVAKIA

HYDAC, s.r.o.
Schmidtova 14
SK-03601 Martin
Tel.: 842 / 35893
Fax: 842 / 35894

SOUTH-AFRICA
(Namibia, Zimbabwe)

Hytec of Southern Africa (Pty) Ltd.
P.O. Box 8
ZA-Maraisburg, 1700 (Transvaal)
Tel.: 11 / 6731210, 6732213
Fax: 11 / 6730212

SPAIN

Bultz S.A.
Paseo de Arriola, 15
E-20009 San Sebastian
Tel.: 43 / 217000
Fax: 43 / 217207
Telex: 36540

SWEDEN

HYDAC Fluidteknik AB
Karlsbodavägen 41, Mariehäll
Box 20112
S-16102 Bromma
Tel.: 8 / 4452970
Fax: 8 / 4452990

SWITZERLAND

RUAL S.A. Hydraulics
Via Cantonale 69
CH-6964 Davesco-Lugano
Tel.: 91 / 935 00 80
Fax: 91 / 942 38 84

RUAL S.A. - T.B. Bern

Zentweg 21
CH-3006 Bern
Tel.: 31 / 9 31 62 44
Fax: 31 / 9 31 66 42

RUAL S.A. - T.B. St. Gallen

Langgasse 91
CH-9008 St. Gallen
Tel.: 71 / 2 42 66 77
Fax: 71 / 2 45 27 90

THAILAND

Pneumax Co., Ltd.
2447/5 New Petburi Road
Near Ekamai Junction
Bangkapi, Huaykwang
T-10310 Bangkok
Tel.: 2 / 3181972, 3180086
Fax: 2 / 3198180

Aerofluid Co. Ltd.
600/441 Moo 14, Paholyothin Rd.
T-Lamlookka Patumthanee 12130
Tel.: 2 / 536-7129, 536-7153,
536-8069, 536-8070,
536-6228, 992-1664-7
Fax: 2 / 536-7131