

WVE Series Shuttle Valves



Description

The HYDAC WVE series are shuttle valves with two inlets and one outlet. The inlet with the higher pressure is automatically connected to the outlet. The other inlet is closed. This complies with DIN-ISO 1219. The shuttle valves are cartridge type valves for installation into manifolds and control blocks. The shuttle valves are ball-seat type valves without leakage

Technical Data

Design

- Seat Valve

Mounting Method

- Cartridge

Nominal Size

- (SAE-5) 1/2"-20 UNF

Weight

- (SAE-5) 1/2"-20 UNF...12g

Mounting Position

- Optional

Material

- Carbon Steel

Direction of Flow

- Optional

Operating Pressure Range

- P max. 5000 psi = 350 bar

Temperature Range

- -4° to 104°F (-20° to 80°C)

Cross-Over Effect on Shut-off

- negligible

Flow Rate

- Max flow rate 5 gpm (20 lpm)
ΔP approx 175 psi (12 bar)
at 5 gpm, 168 SSU, 104°F oil

Model Code

WVE-1/2-20UNF-0

Part Number

00710128

Hydraulic Symbol

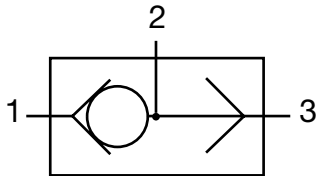

Dimensions

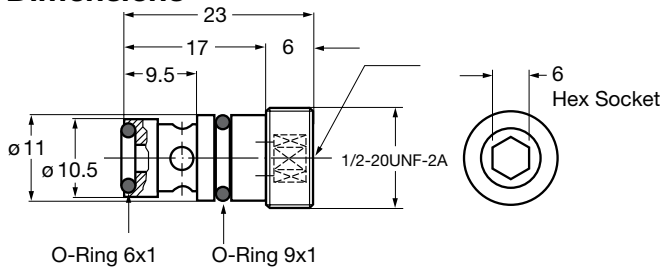

Installation Diagram

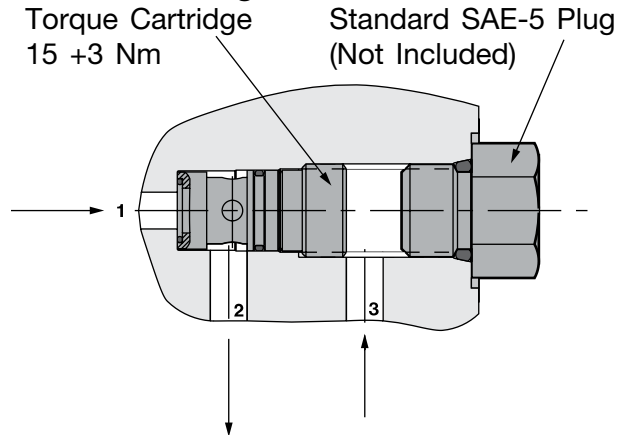

Cavity Diagram

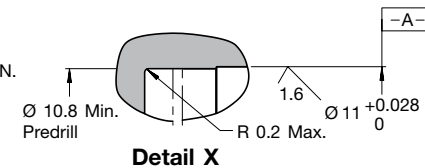
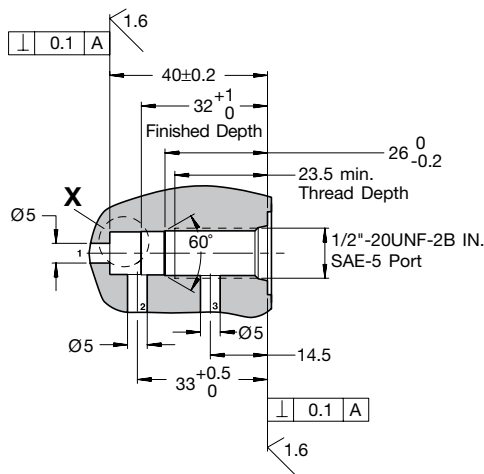

Dimensions are for general information only, all critical dimensions should be verified by requesting a certified print. Dimensions are in mm